

# HARDIN COUNTY WATER DISTRICT NO. 2 MELROSE ROAD AND FLINT HILL ROAD WATERLINE EXTENSIONS HARDIN COUNTY, KENTUCKY REVISED JANUARY 2025

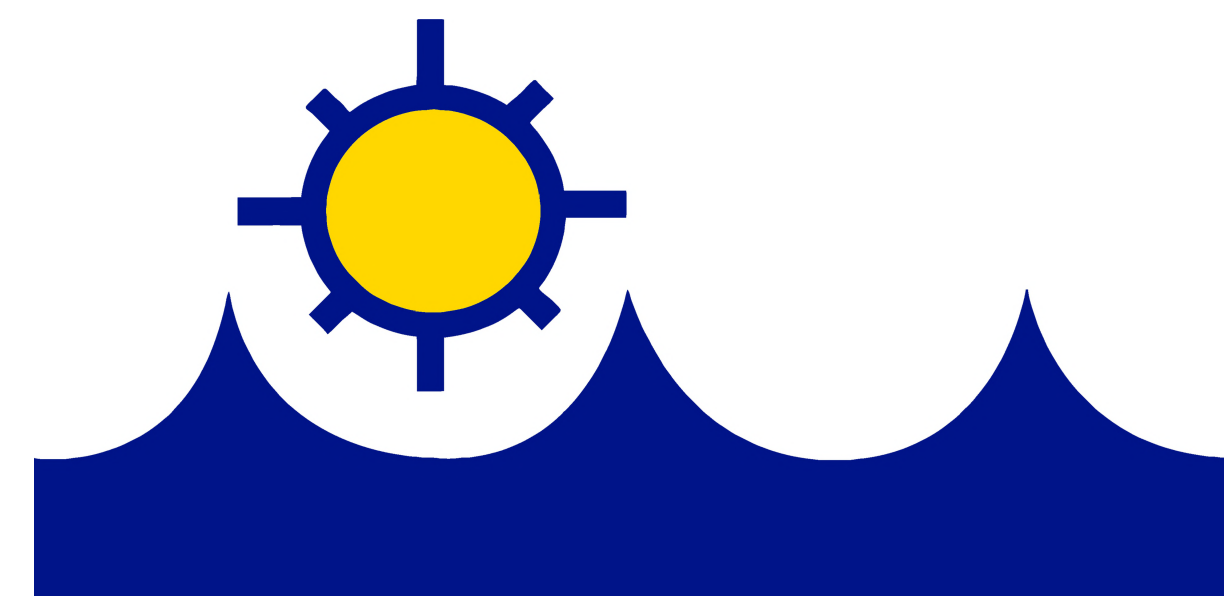
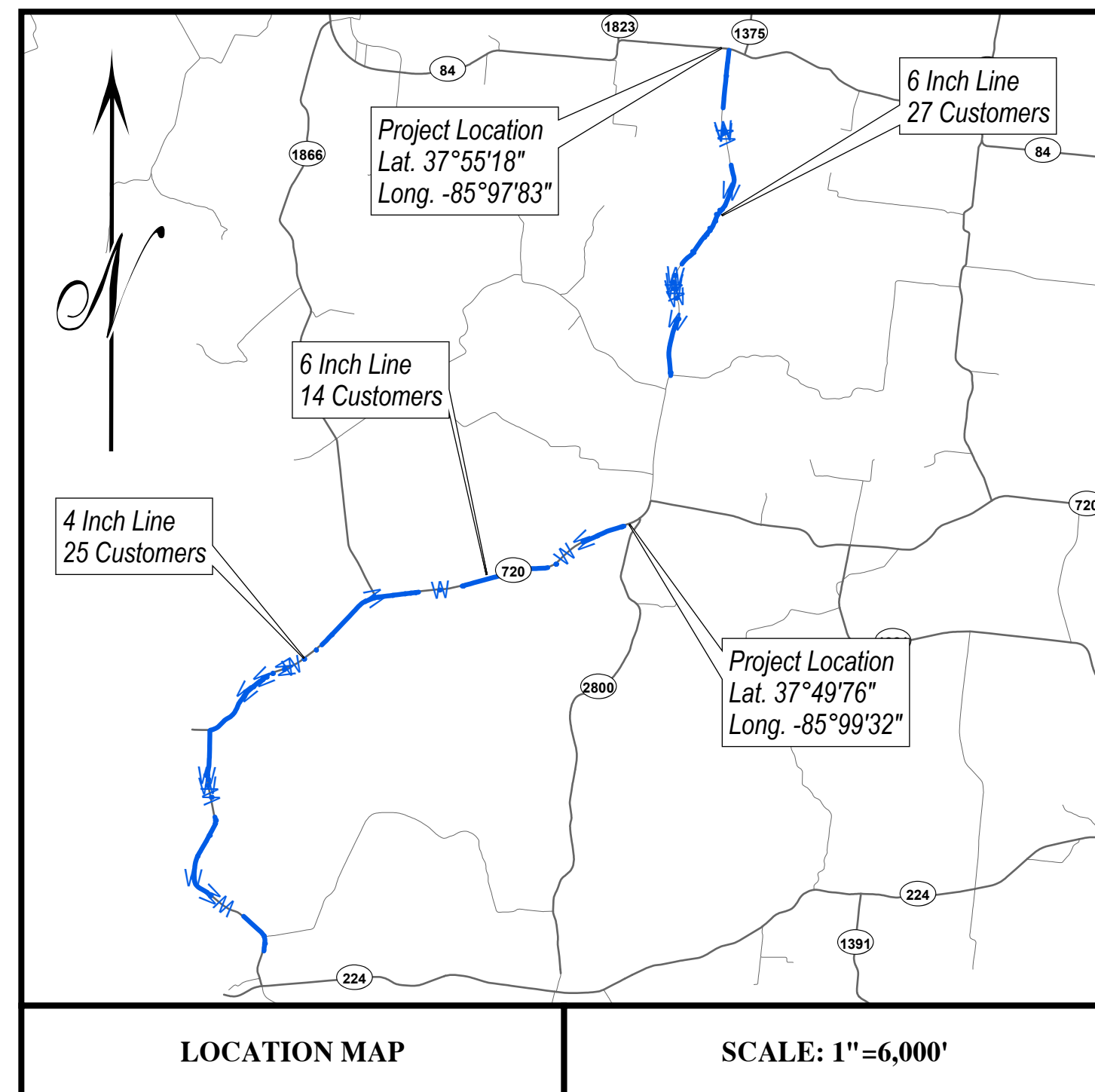

Hardin County Water  
District No. 2

## INDEX OF SHEETS

DESCRIPTION	SHEET
COVER SHEET	1
GENERAL NOTES,	2
PLAN SHEETS	3-18
DETAILS	19

Prepared By:

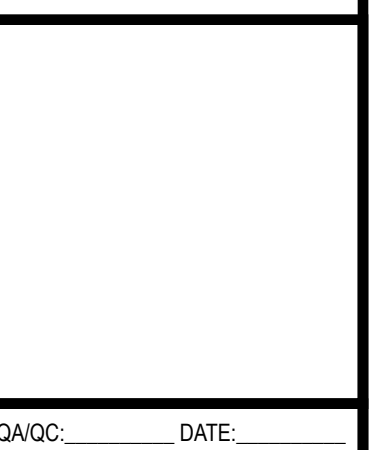
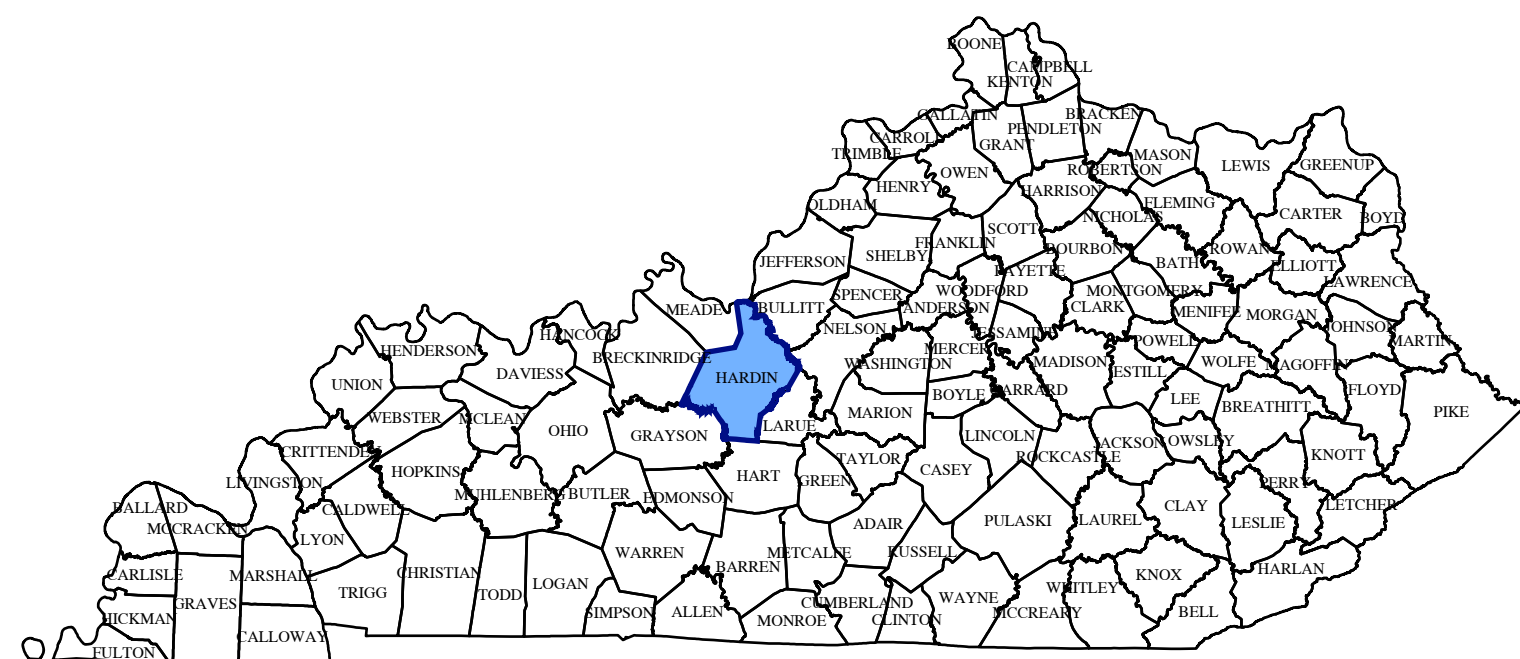

**General Notes**

1. The Contractor shall fully comply will all Local, State and Federal safety and environmental regulations governing utility construction.
2. The Contractor shall verify the location of all existing utilities prior to beginning construction. Contact Kentucky811 at 811, 1-800-752-6007 (nationwide), or www.kentucky811.org at least 72 hours prior to beginning construction. Contractor shall be responsible for any and all damages to existing utilities resulting from negligence and/or failure to properly locate and protect said utilities.
3. Existing and proposed water main locations shall be verified by Hardin County Water District No. 2 prior to construction.
4. The Contractor shall notify the District forty-eight (48) hours prior to beginning water line construction, including to inspect/witness taps and pressure tests.
5. Construction practices and procedures shall conform to current AWWA standards and also conform to Hardin County Water District No. 2 Standards Specifications and Details for water main design, construction and materials. Specifications are on file at the District office. The Contractor shall refer to said specifications and details for all typical detail drawings.
6. Submit shop drawings to the District for review and approval prior to beginning work.
7. All water lines shall conform to ASTM specifications D-1784, C900-DR18 joints shall be slip-type with rubber gaskets conforming to ASTM-1869.
8. Fittings shall be Ductile Iron in accordance with AWWA C110 or C153 and shall be manufactured for the size and pressure class of the line on which they are used.
9. All valves shall conform to AWWA C509. Blow-off valves smaller than 4" shall conform to AWWA C500.
10. All water line crossing proposed paved surface shall be backfilled full depth with crushed stone.
11. All pipe and fittings shall have a minimum of 6" bedding of dirt under and on both sides of pipe unless otherwise specified. All pipe and fittings shall be backfilled with dirt unless otherwise specified.
12. All fittings: 90° bends, tees, etc., shall be blocked with a minimum of 12" poured concrete against undisturbed soil.
13. Water lines shall be installed a minimum 30" below the elevation of the finished roadway immediately adjacent to the pipe. When on State right-of-way, water lines shall be installed a minimum 42" below the elevation of the finished roadway immediately adjacent to the pipe.
14. All fire hydrants shall be standard 3-way 5 1/4" breakaway type with a minimum 3 1/2-foot bury, turning left to open and right to close. All fire hydrants shall be painted Body - National Blue and Caps - Silver in color. Fire hydrants must be installed with the base of the fire hydrant 2-3" above final grade.
15. Valves shall not be installed within sidewalks, curb or gutter, or driveways. All valves shall have cast iron valve boxes extending no more than 1/2" above final grade or 2" in un-sodded areas. Gate valves shall turn right to close and turn left to open.
16. Only District personnel shall operate the District's existing valves.
17. The Contactor shall notify the District and all property owners 24 hours prior to cutting any existing water service off. Water service shall not be interrupted for more than 4 hours at any one time unless otherwise directed

by the District.

18. All water lines and services, regardless of material, shall have a tracer wire installed along the top half of the pipe.

19. After installation, all water lines shall be pressure tested (150 PSI @ 2 hours), disinfected with a chlorine solution (50 PPM initially and 25 PPM after 24 hours), and have passing bacteriological tests prior to being placed into service.



DRAWN BY: AO
CHECKED BY: BH
DATE: 2/5/2025
SCALE: NTS
REVISIONS

MELROSE ROAD AND  
FLINT HILL ROAD  
Waterline Extension  
Hardin County, Kentucky



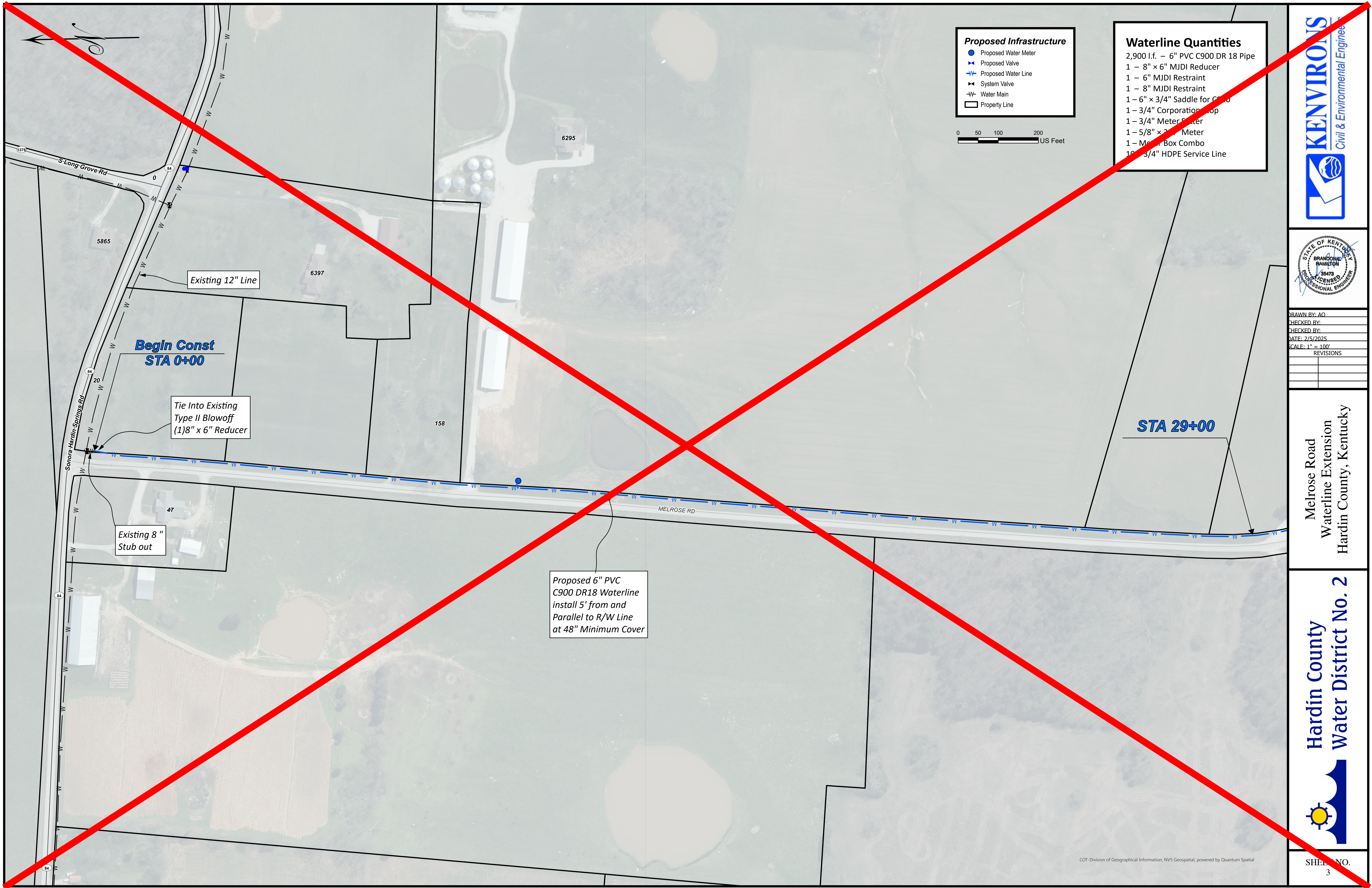

- Proposed Infrastructure**
- Proposed Water Meter
  - ✚ Proposed Valve
  - Proposed Water Line
  - ✚ System Valve
  - Water Main
  - Property Line

0 50 100 200 US Feet

- Waterline Quantities**
- 2,900 l.f. — 6" PVC C900 DR 18 Pipe
  - 1 — 8" x 6" MJDI Reducer
  - 1 — 6" MJDI Restraint
  - 1 — 8" MJDI Restraint
  - 1 — 6" x 3/4" Saddle for C900
  - 1 — 3/4" Corporation Stop
  - 1 — 3/4" Meter Socket
  - 1 — 5/8" x 3/4" Meter
  - 1 — Meter Box Combo
  - 10 — 3/4" HDPE Service Line

Existing 12" Line

Begin Const  
STA 0+00

Tie Into Existing  
Type II Blowoff  
(1)8" x 6" Reducer

Existing 8"  
Stub out

Proposed 6" PVC  
C900 DR18 Waterline  
install 5' from and  
Parallel to R/W Line  
at 48" Minimum Cover

STA 29+00



DRAWN BY: AQ  
CHECKED BY:  
DATE: 2/5/2025  
SCALE: 1" = 100'  
REVISIONS

Melrose Road  
Waterline Extension  
Hardin County, Kentucky

Hardin County  
Water District No. 2

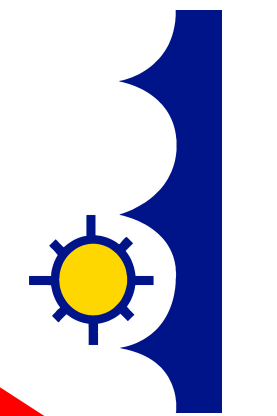

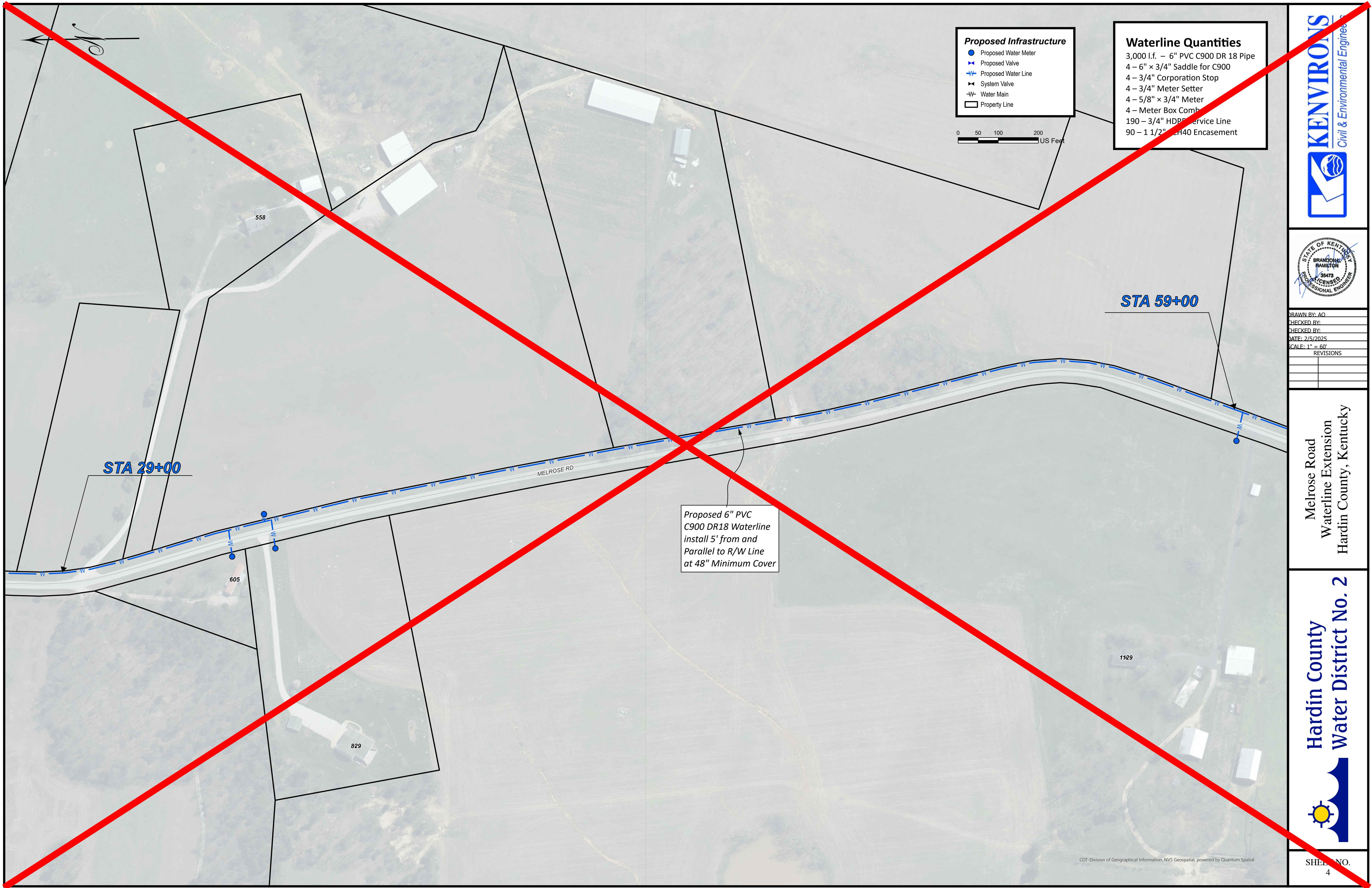

- Proposed Infrastructure**
- Proposed Water Meter
  - ⚡ Proposed Valve
  - Proposed Water Line
  - ⚡ System Valve
  - W- Water Main
  - Property Line

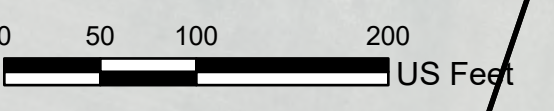

- Waterline Quantities**
- 3,000 l.f. - 6" PVC C900 DR 18 Pipe
  - 4 - 6" x 3/4" Saddle for C900
  - 4 - 3/4" Corporation Stop
  - 4 - 3/4" Meter Setter
  - 4 - 5/8" x 3/4" Meter
  - 4 - Meter Box Comb
  - 190 - 3/4" HDPE Service Line
  - 90 - 1 1/2" CH40 Encasement



DRAWN BY: AO
CHECKED BY:
DATE: 2/5/2025
SCALE: 1" = 60'
REVISIONS

Melrose Road  
Waterline Extension  
Hardin County, Kentucky

Hardin County  
Water District No. 2

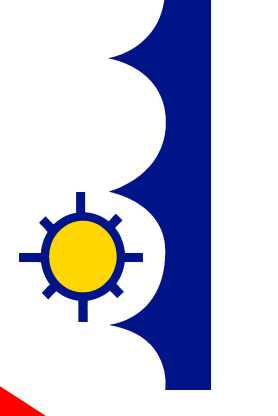

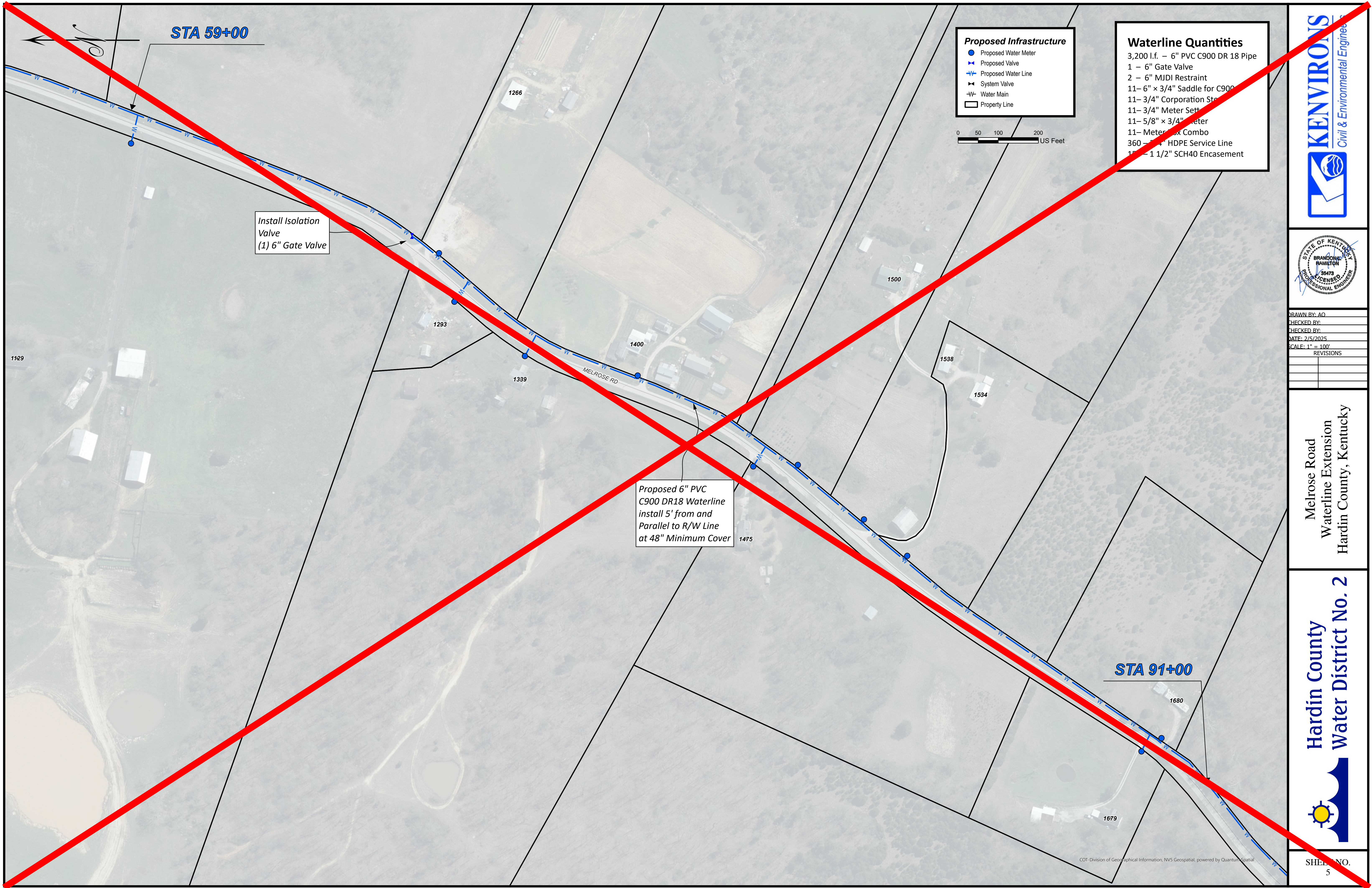

STA 59+00

Install Isolation Valve  
(1) 6" Gate Valve

Proposed 6" PVC C900 DR18 Waterline install 5' from and Parallel to R/W Line at 48" Minimum Cover

STA 91+00

**Proposed Infrastructure**

- Proposed Water Meter
- ⊕ Proposed Valve
- Proposed Water Line
- ⊕ System Valve
- W- Water Main
- ▭ Property Line

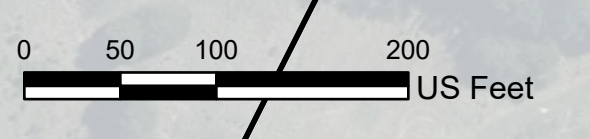

**Waterline Quantities**

- 3,200 l.f. — 6" PVC C900 DR 18 Pipe
- 1 — 6" Gate Valve
- 2 — 6" MJDI Restraint
- 11— 6" x 3/4" Saddle for C900
- 11— 3/4" Corporation Stop
- 11— 3/4" Meter Sett
- 11— 5/8" x 3/4" Meter
- 11— Meter Box Combo
- 360 — 4" HDPE Service Line
- 11 — 1 1/2" SCH40 Encasement



DRAWN BY: AQ  
 CHECKED BY:  
 DATE: 2/5/2025  
 SCALE: 1" = 100'  
 REVISIONS

Melrose Road  
 Waterline Extension  
 Hardin County, Kentucky

COT - Division of Geographical Information, NVS Geospatial, powered by Quantum Spatial

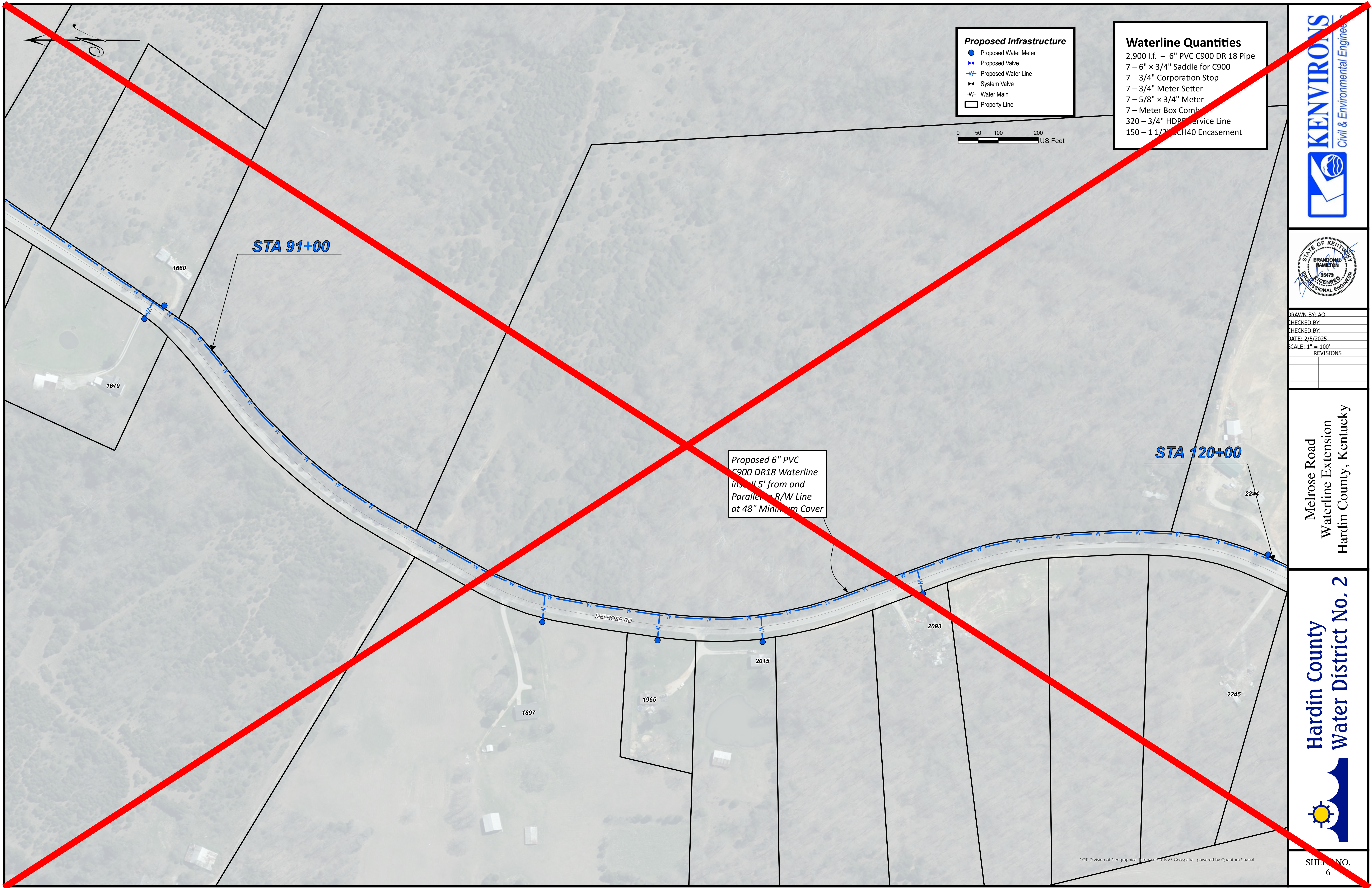

- Proposed Infrastructure**
- Proposed Water Meter
  - ⊕ Proposed Valve
  - Proposed Water Line
  - ⊕ System Valve
  - W— Water Main
  - Property Line



- Waterline Quantities**
- 2,900 l.f. - 6" PVC C900 DR 18 Pipe
  - 7 - 6" x 3/4" Saddle for C900
  - 7 - 3/4" Corporation Stop
  - 7 - 3/4" Meter Setter
  - 7 - 5/8" x 3/4" Meter
  - 7 - Meter Box Comb
  - 320 - 3/4" HDPE Service Line
  - 150 - 1 1/2" SCH40 Encasement

Proposed 6" PVC C900 DR18 Waterline Installed 5' from and Parallel to R/W Line at 48" Minimum Cover

STA 91+00

STA 120+00



DRAWN BY: AO  
 CHECKED BY:  
 DATE: 2/5/2025  
 SCALE: 1" = 100'  
 REVISIONS

Melrose Road  
 Waterline Extension  
 Hardin County, Kentucky

Hardin County  
 Water District No. 2

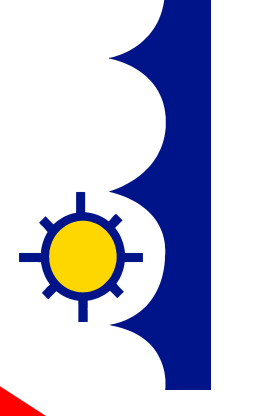

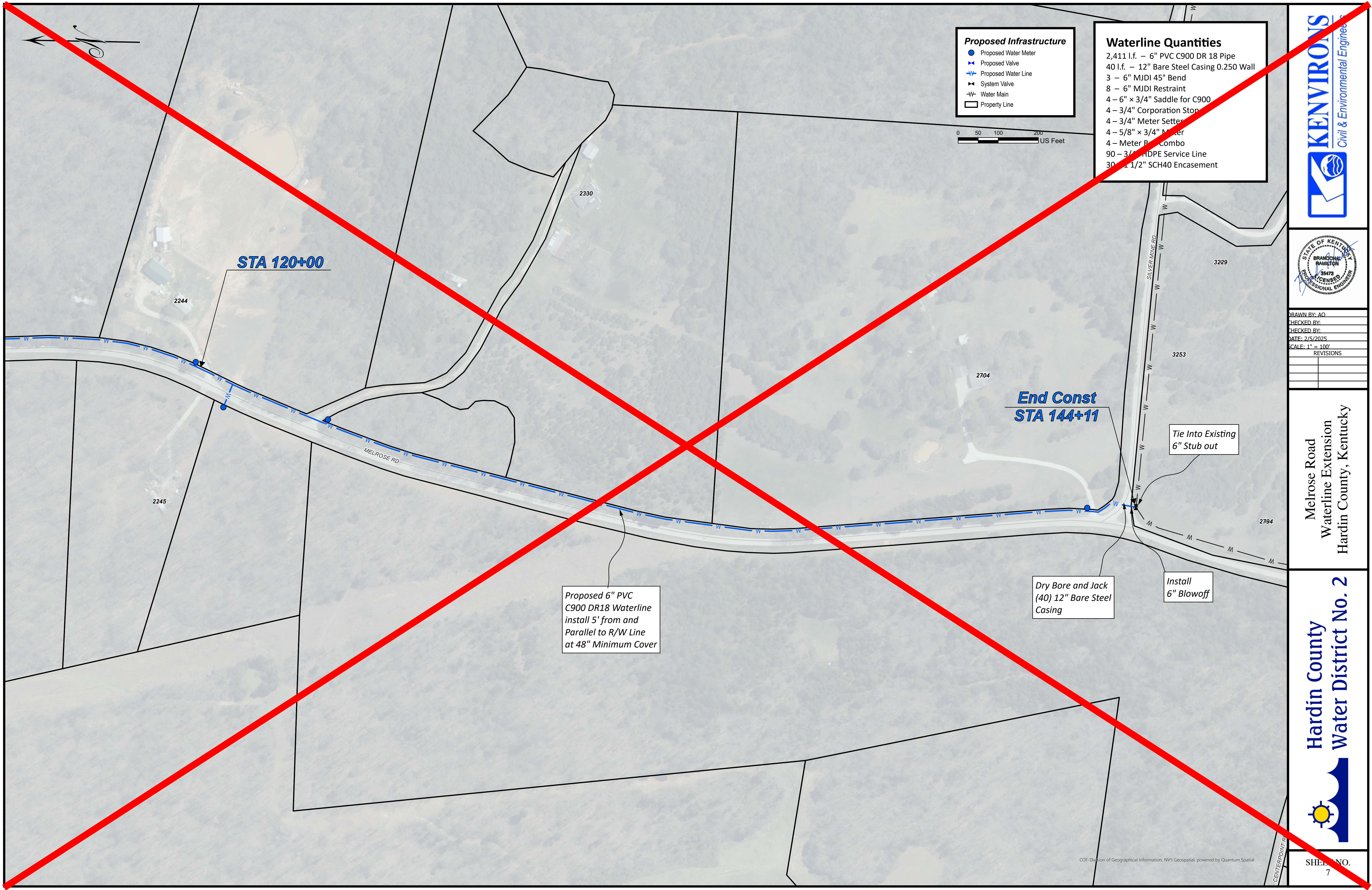

- Proposed Infrastructure**
- Proposed Water Meter
  - ⊕ Proposed Valve
  - Proposed Water Line
  - ⊕ System Valve
  - W- Water Main
  - Property Line

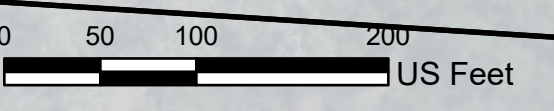

- Waterline Quantities**
- 2,411 l.f. – 6" PVC C900 DR 18 Pipe
  - 40 l.f. – 12" Bare Steel Casing 0.250 Wall
  - 3 – 6" MJDI 45° Bend
  - 8 – 6" MJDI Restraint
  - 4 – 6" x 3/4" Saddle for C900
  - 4 – 3/4" Corporation Stop
  - 4 – 3/4" Meter Setting
  - 4 – 5/8" x 3/4" Meter
  - 4 – Meter Box Combo
  - 90 – 3/4" HDPE Service Line
  - 30 – 1 1/2" SCH40 Encasement



DRAWN BY: AO  
 CHECKED BY:  
 DATE: 2/5/2025  
 SCALE: 1" = 100'  
 REVISIONS

Melrose Road  
 Waterline Extension  
 Hardin County, Kentucky

Hardin County  
 Water District No. 2

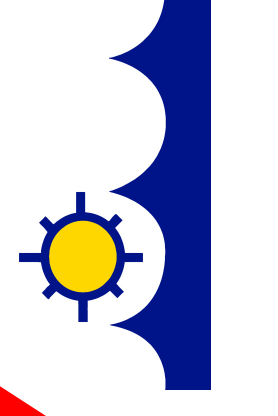

COI - Division of Geographical Information, NVS Geospatial, powered by Quantum Spatial



**Waterline Quantities**

3,200 l.f.	6" PVC C900 DR 18 Pipe
1	6" MJDI Restraint
3	6" x 3/4" Saddle for C900
3	3/4" Corporation Stop
3	3/4" Meter Setter
3	5/8" x 3/4" Meter
3	Meter Box Combo
80	3/4" HDPE Service Line
30	1 1/2" SCH40 Encasement



DRAWN BY: AO  
 CHECKED BY:  
 CHECKED BY:  
 DATE: 2/5/2025  
 SCALE: 1" = 100'  
 REVISIONS

Flint Hill Rd.  
 Waterline Extension  
 Hardin County, Kentucky

Hardin County  
 Water District No. 2

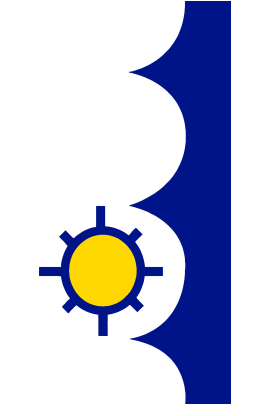

SHEET NO.  
 8

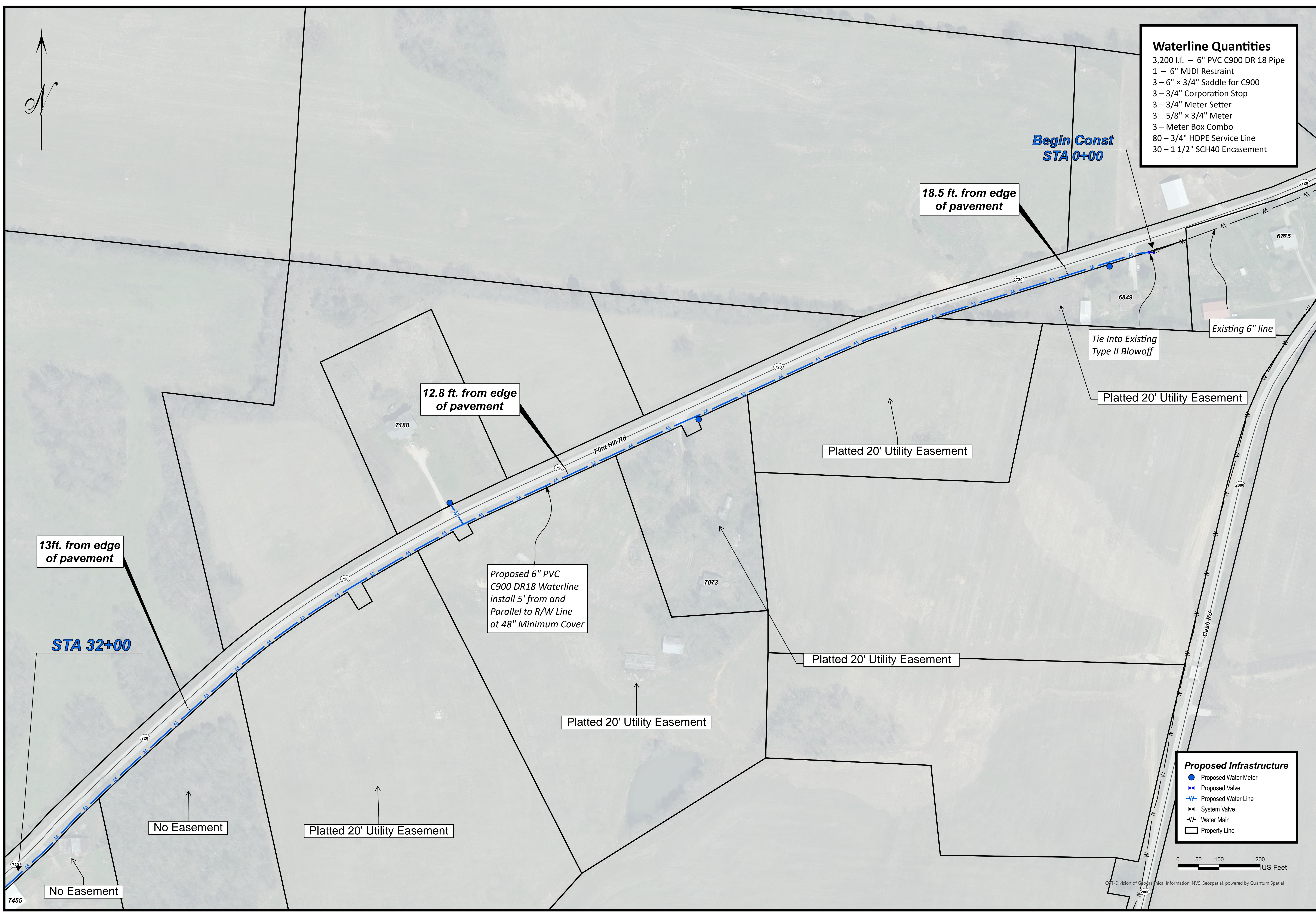

© 2025 Division of Geographical Information, NVS Geospatial, powered by Quantum Spatial



**Waterline Quantities**

- 3,200 l.f. - 6" PVC C900 DR 18 Pipe
- 3 - 6" x 3/4" Saddle for C900
- 3 - 3/4" Corporation Stop
- 3 - 3/4" Meter Setter
- 3 - 5/8" x 3/4" Meter
- 3 - Meter Box Combo
- 30 - 3/4" HDPE Service Line

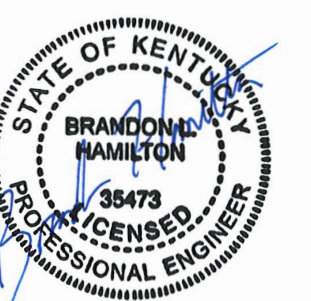

DRAWN BY: AO  
 CHECKED BY:  
 DATE: 2/5/2025  
 SCALE: 1" = 100'

NO.	REVISIONS

Flint Hill Rd.  
 Waterline Extension  
 Hardin County, Kentucky

Hardin County  
 Water District No. 2

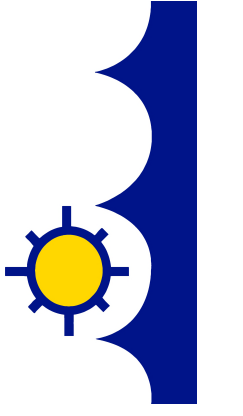

SHEET NO.  
 9

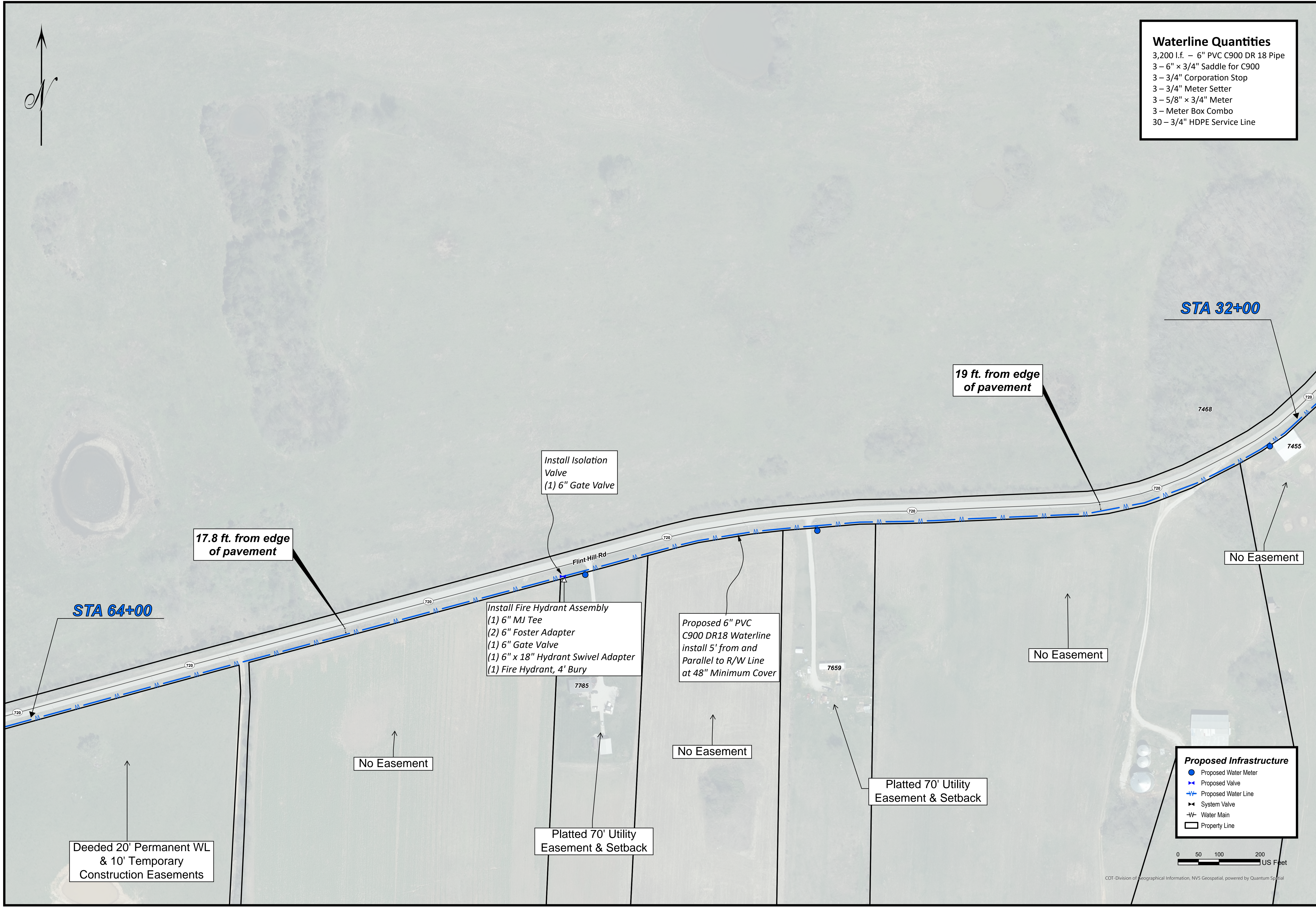

COT - Division of Geographical Information, NVS Geospatial, powered by Quantum Spatial



**Waterline Quantities**

- 3,000 l.f. - 6" PVC C900 DR 18 Pipe
- 4 - 6" x 3/4" Saddle for C900
- 4 - 3/4" Corporation Stop
- 4 - 3/4" Meter Setter
- 4 - 5/8" x 3/4" Meter
- 4 - Meter Box Combo
- 40 - 3/4" HDPE Service Line



DRAWN BY: AO  
 CHECKED BY:  
 CHECKED BY:  
 DATE: 2/5/2025  
 SCALE: 1" = 100'

NO.	REVISIONS

Flint Hill Rd.  
 Waterline Extension  
 Hardin County, Kentucky

Hardin County  
 Water District No. 2

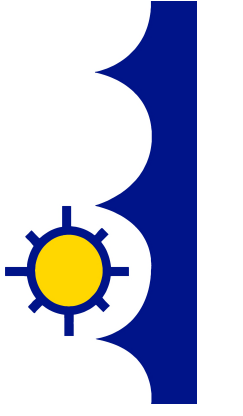

SHEET NO.  
 10

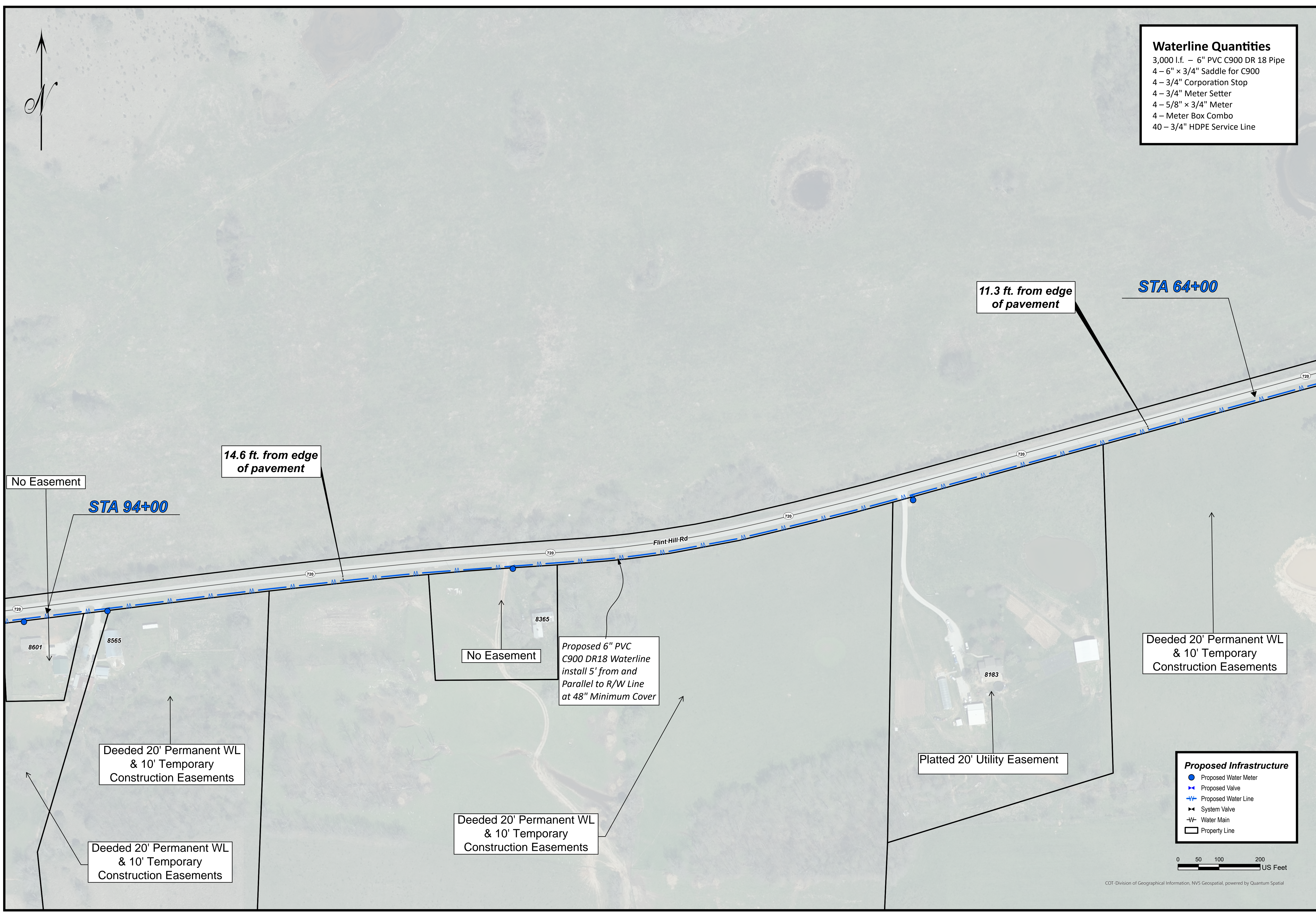

11.3 ft. from edge of pavement

STA 64+00

14.6 ft. from edge of pavement

No Easement

STA 94+00

No Easement

Proposed 6" PVC C900 DR18 Waterline install 5' from and Parallel to R/W Line at 48" Minimum Cover

Platted 20' Utility Easement

Deeded 20' Permanent WL & 10' Temporary Construction Easements

Deeded 20' Permanent WL & 10' Temporary Construction Easements

Deeded 20' Permanent WL & 10' Temporary Construction Easements

Deeded 20' Permanent WL & 10' Temporary Construction Easements

**Proposed Infrastructure**

- Proposed Water Meter
- Proposed Valve
- Proposed Water Line
- System Valve
- Water Main
- Property Line

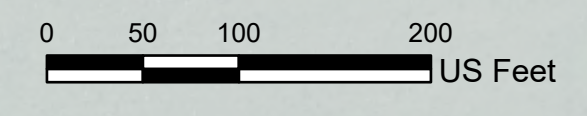

COT - Division of Geographical Information, NVS Geospatial, powered by Quantum Spatial

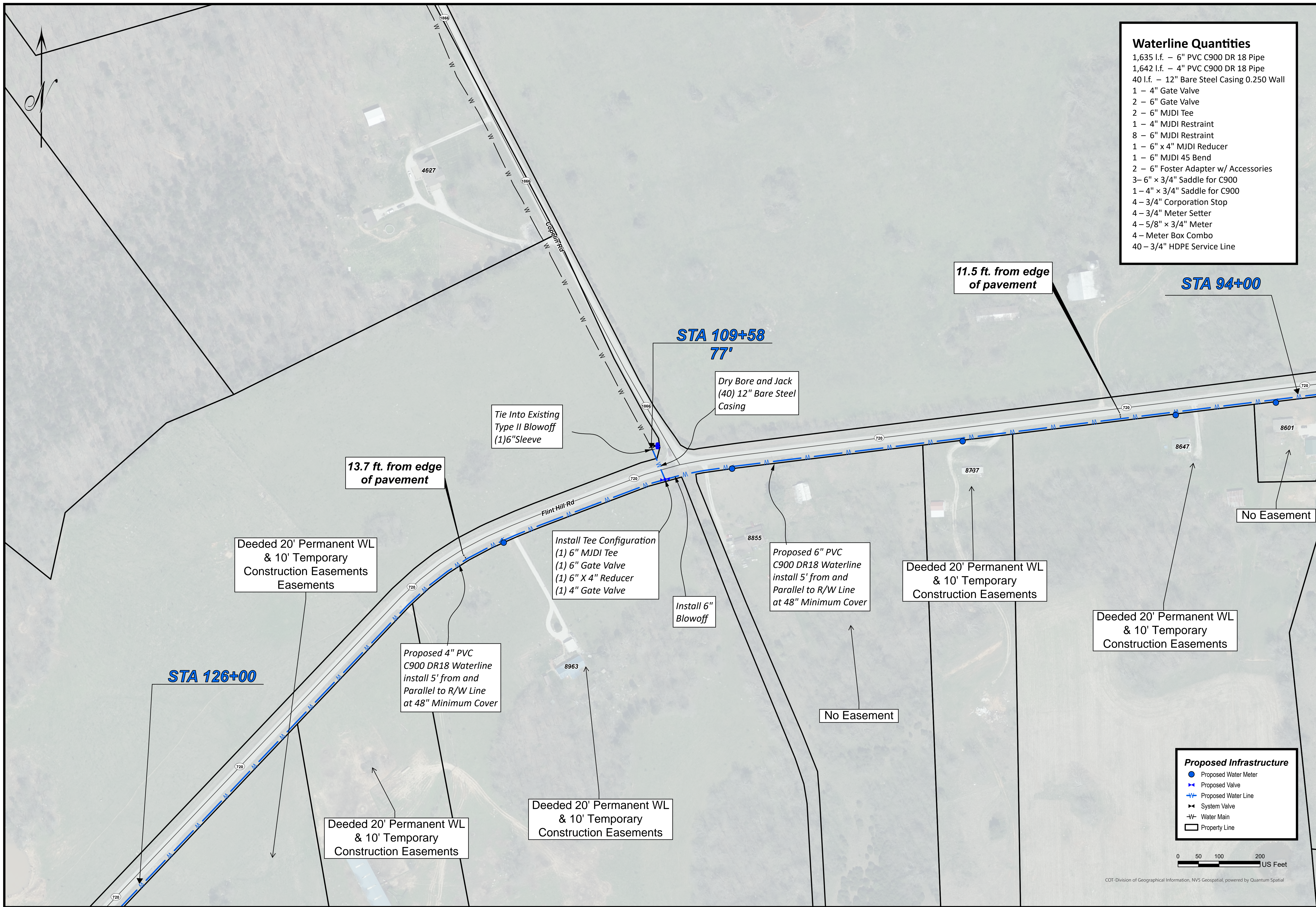

DRAWN BY: AO  
 CHECKED BY:  
 CHECKED BY:  
 DATE: 2/5/2025  
 SCALE: 1" = 100'

Flint Hill Rd.  
 Waterline Extension  
 Hardin County, Kentucky

Hardin County  
 Water District No. 2



**Waterline Quantities**  
 3,100 l.f. - 4" PVC C900 DR 18 Pipe  
 3 - 4" x 3/4" Saddle for C900  
 3 - 3/4" Corporation Stop  
 3 - 3/4" Meter Setter  
 3 - 5/8" x 3/4" Meter  
 3 - Meter Box Combo  
 30 - 3/4" HDPE Service Line

12 ft. from edge of pavement

STA 126+00

Deeded 20' Permanent WL & 10' Temporary Construction Easements

12.7 ft. from edge of pavement

Proposed 4" PVC C900 DR18 Waterline install 5' from and Parallel to R/W Line at 48" Minimum Cover

Deeded 20' Permanent WL & 10' Temporary Construction Easements

Platted 20' Utility Easement

Deeded 20' Permanent WL & 10' Temporary Construction Easements

Platted 20' Utility Easement

STA 157+00

Platted 20' Utility Easement

**Proposed Infrastructure**  
 ● Proposed Water Meter  
 + Proposed Valve  
 + Proposed Water Line  
 + System Valve  
 -W- Water Main  
 □ Property Line

0 50 100 200 US Feet

COT - Division of Geographical Information, NVS Geospatial, powered by Quantum Spatial



DRAWN BY: AO  
 CHECKED BY:  
 DATE: 2/5/2025  
 SCALE: 1" = 100'  
 REVISIONS

Flint Hill Rd.  
 Waterline Extension  
 Hardin County, Kentucky

Hardin County  
 Water District No. 2

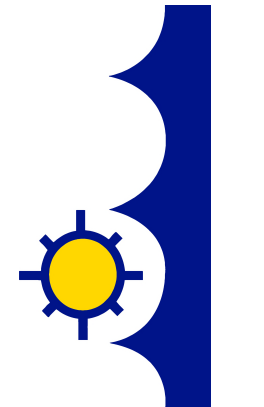

SHEET NO.  
 12



- Waterline Quantities**
- 2,400 l.f. - 4" PVC C900 DR 18 Pipe
  - 1 - 4" Gate Valve
  - 2 - 4" MJDI Restraint
  - 9 - 4" x 3/4" Saddle for C900
  - 9 - 3/4" Corporation Stop
  - 9 - 3/4" Meter Setter
  - 9 - 5/8" x 3/4" Meter
  - 9 - Meter Box Combo
  - 9 - Pressure Regulators
  - 240 - 3/4" HDPE Service Line
  - 90 - 1 1/2" SCH40 Encasement



DRAWN BY: AO  
 CHECKED BY:  
 DATE: 2/5/2025  
 SCALE: 1" = 100'

NO.	REVISIONS

Flint Hill Rd.  
 Waterline Extension  
 Hardin County, Kentucky

Hardin County  
 Water District No. 2

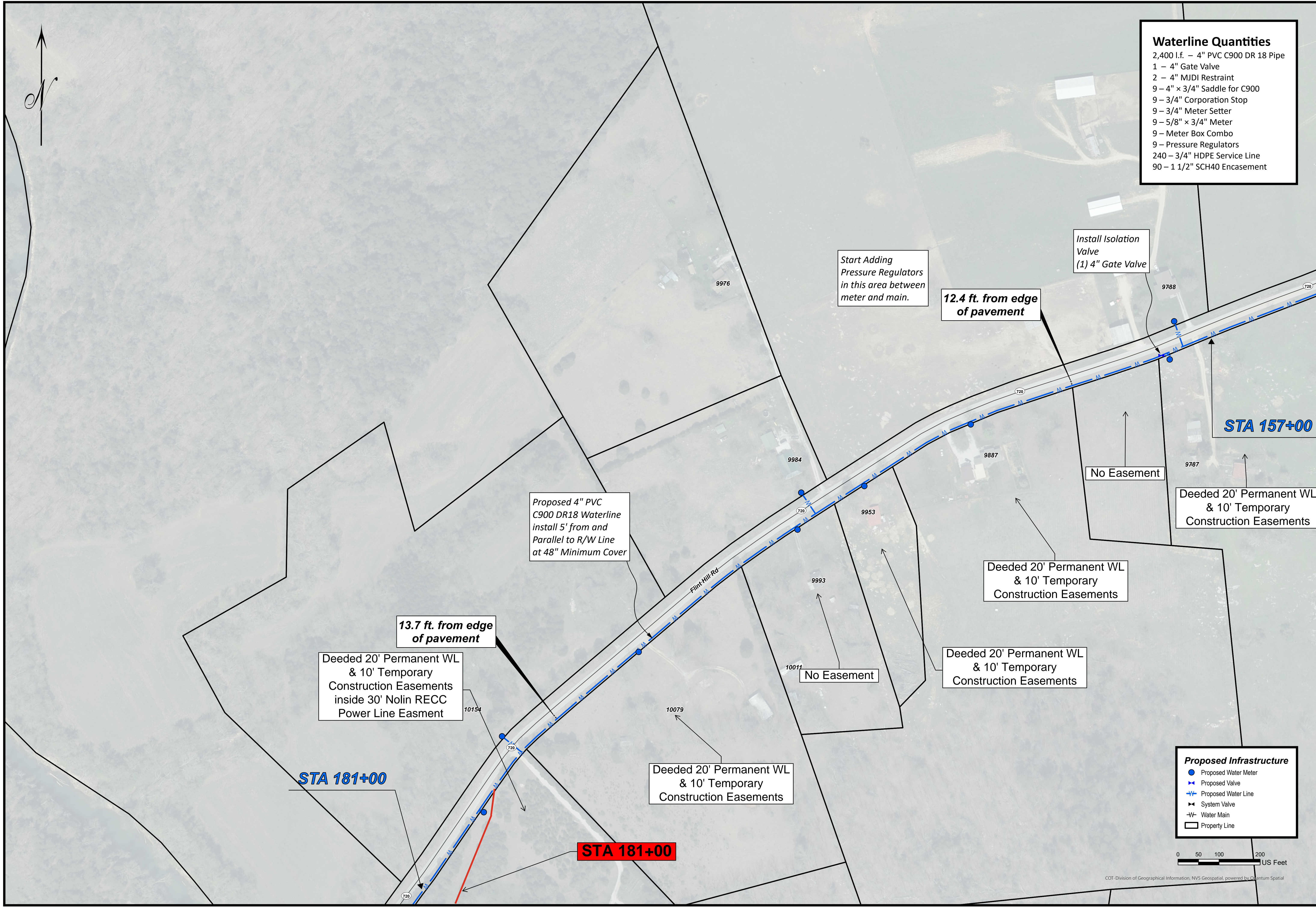
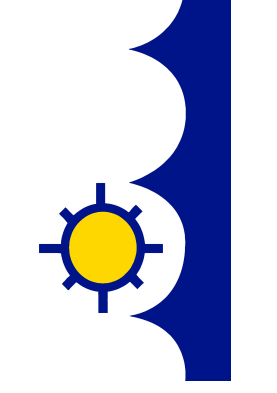

12.4 ft. from edge of pavement

Start Adding Pressure Regulators in this area between meter and main.

Install Isolation Valve (1) 4" Gate Valve

STA 157+00

No Easement

Deeded 20' Permanent WL & 10' Temporary Construction Easements

Deeded 20' Permanent WL & 10' Temporary Construction Easements

Deeded 20' Permanent WL & 10' Temporary Construction Easements

No Easement

Deeded 20' Permanent WL & 10' Temporary Construction Easements

13.7 ft. from edge of pavement

Deeded 20' Permanent WL & 10' Temporary Construction Easements inside 30' Nolin RECC Power Line Easement

STA 181+00

STA 181+00

- Proposed Infrastructure**
- Proposed Water Meter
  - ⊕ Proposed Valve
  - ⊕ Proposed Water Line
  - ⊕ System Valve
  - Water Main
  - Property Line

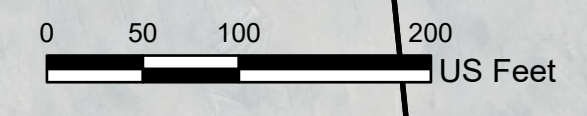

COT - Division of Geographical Information, NVS Geospatial, powered by Quantum Spatial

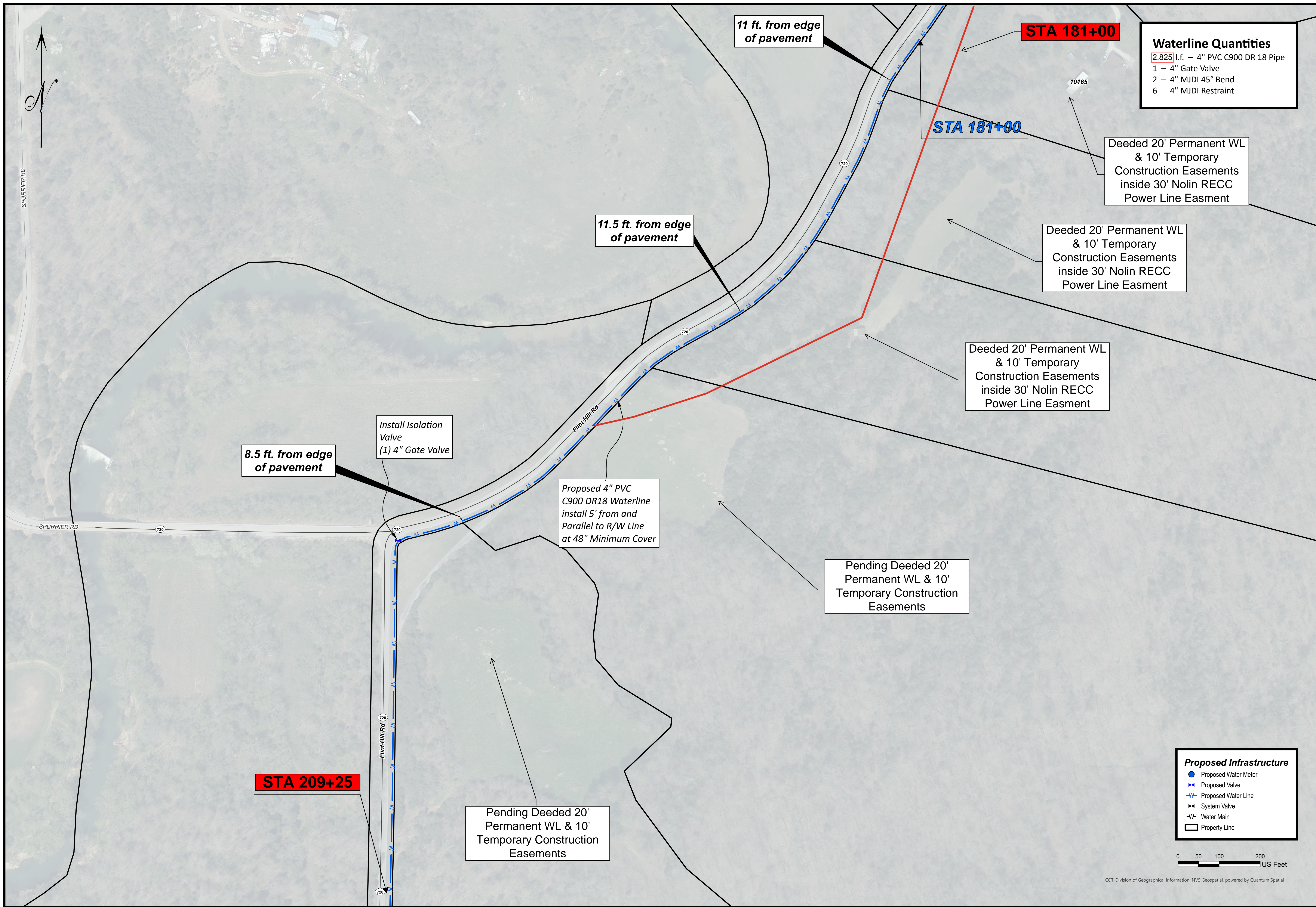

**Waterline Quantities**  
 2,825 l.f. - 4" PVC C900 DR 18 Pipe  
 1 - 4" Gate Valve  
 2 - 4" MJDI 45° Bend  
 6 - 4" MJDI Restraint

Deeded 20' Permanent WL & 10' Temporary Construction Easements inside 30' Nolin RECC Power Line Easment

Deeded 20' Permanent WL & 10' Temporary Construction Easements inside 30' Nolin RECC Power Line Easment

Deeded 20' Permanent WL & 10' Temporary Construction Easements inside 30' Nolin RECC Power Line Easment

Pending Deeded 20' Permanent WL & 10' Temporary Construction Easements

Pending Deeded 20' Permanent WL & 10' Temporary Construction Easements

8.5 ft. from edge of pavement

Install Isolation Valve (1) 4" Gate Valve

Proposed 4" PVC C900 DR18 Waterline install 5' from and Parallel to R/W Line at 48" Minimum Cover

11 ft. from edge of pavement

11.5 ft. from edge of pavement

**STA 181+00**

STA 181+00

**STA 209+25**

- Proposed Infrastructure**
- Proposed Water Meter
  - ⊕ Proposed Valve
  - ⊕ Proposed Water Line
  - ⊕ System Valve
  - W— Water Main
  - Property Line

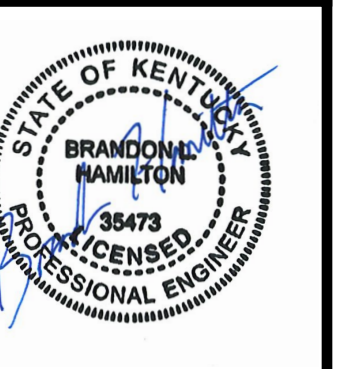
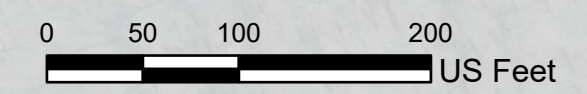

DRAWN BY: AO
CHECKED BY:
CHECKED BY:
DATE: 2/5/2025
SCALE: 1" = 100'
REVISIONS

Flint Hill Rd.  
 Waterline Extension  
 Hardin County, Kentucky

**Hardin County**  
**Water District No. 2**

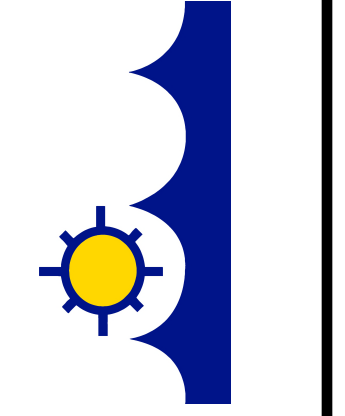

COT-Division of Geographical Information, NVS Geospatial, powered by Quantum Spatial



**Waterline Quantities**  
 2,100 l.f. - 4" PVC C900 DR 18 Pipe  
 5 - 4" x 3/4" Saddle for C900  
 5 - 3/4" Corporation Stop  
 5 - 3/4" Meter Setter  
 5 - 5/8" x 3/4" Meter  
 5 - Meter Box Combo  
 5 - Pressure Regulators  
 150 - 3/4" HDPE Service Line  
 60 - 1 1/2" SCH40 Encasement

**STA 209+25**

Pending Deeded 20'  
 Permanent WL & 10'  
 Temporary Construction  
 Easements

Proposed 4" PVC  
 C900 DR18 Waterline  
 install 5' from and  
 Parallel to R/W Line  
 at 48" Minimum Cover

Platted 20' Utility Easement

Platted 20' Utility Easement

**STA 230+25**

Pending Deeded 20'  
 Permanent WL & 10'  
 Temporary Construction  
 Easements

**Proposed Infrastructure**  
 ● Proposed Water Meter  
 + Proposed Valve  
 + Proposed Water Line  
 + System Valve  
 -W Water Main  
 □ Property Line

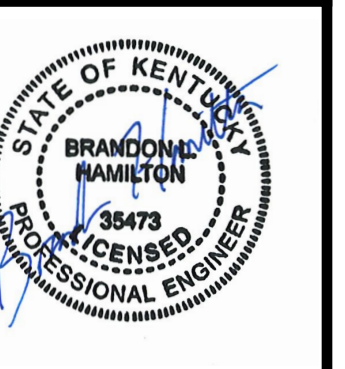
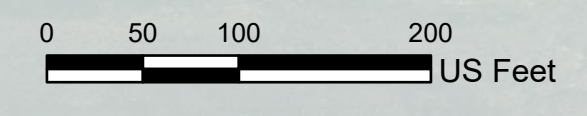

DRAWN BY: AO
CHECKED BY:
CHECKED BY:
DATE: 2/5/2025
SCALE: 1" = 100'
REVISIONS

Flint Hill Rd.  
 Waterline Extension  
 Hardin County, Kentucky

**Hardin County  
 Water District No. 2**

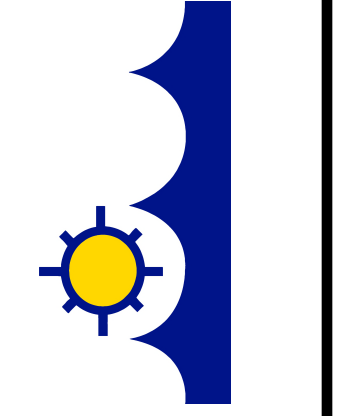

COT-Division of Geographical Information, NVS Geospatial, powered by Quantum Spatial



Platted 20' Utility Easement

**STA 230+25**

Proposed 4" PVC C900 DR18 Waterline install 5' from and Parallel to R/W Line at 48" Minimum Cover

Pending Deeded 20' Permanent WL & 10' Temporary Construction Easements

**Waterline Quantities**

- 2,300 l.f. - 4" PVC C900 DR 18 Pipe
- 1 - 4" Gate Valve
- 2 - 4" MJDI Restraint
- 3 - 4" x 3/4" Saddle for C900
- 3 - 3/4" Corporation Stop
- 3 - 3/4" Meter Setter
- 3 - 5/8" x 3/4" Meter
- 3 - Meter Box Combo
- 3 - Pressure Regulators
- 30 - 3/4" HDPE Service Line

Platted 20' Utility Easement

11223

11255

Install Isolation Valve (1) 4" Gate Valve

Pending Deeded 20' Permanent WL & 10' Temporary Construction Easements

Platted 20' Utility Easement 094-00-00-003.02

11417

Platted 20' Utility Easement

**STA 253+25**

Platted 20' Utility Easement

**Proposed Infrastructure**

- Proposed Water Meter
- ⊕ Proposed Valve
- ⊕ Proposed Water Line
- ⊕ System Valve
- ⊕ Water Main
- Property Line

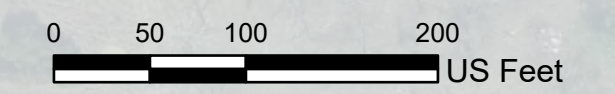

COT - Division of Geographical Information, NVS Geospatial, powered by Quantum Spatial



DRAWN BY: AO
CHECKED BY:
CHECKED BY:
DATE: 2/5/2025
SCALE: 1" = 100'
REVISIONS

Flint Hill Rd.  
Waterline Extension  
Hardin County, Kentucky

Hardin County  
Water District No. 2

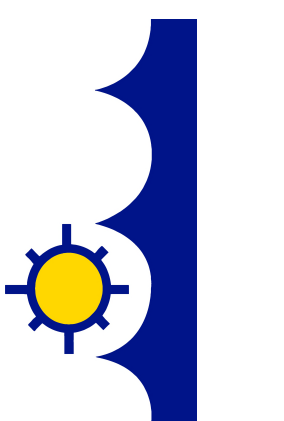

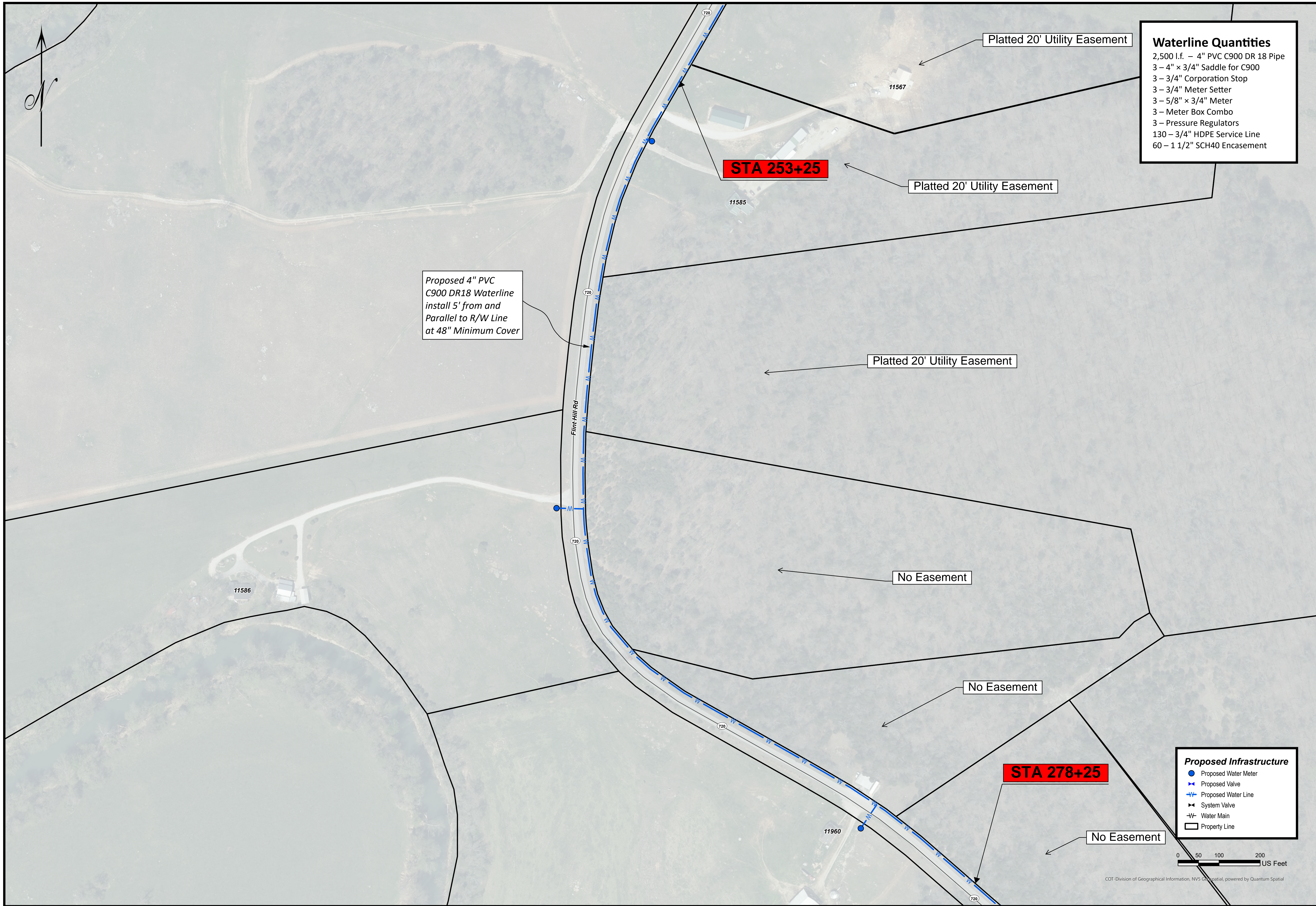

**Waterline Quantities**  
 2,500 l.f. – 4" PVC C900 DR 18 Pipe  
 3 – 4" x 3/4" Saddle for C900  
 3 – 3/4" Corporation Stop  
 3 – 3/4" Meter Setter  
 3 – 5/8" x 3/4" Meter  
 3 – Meter Box Combo  
 3 – Pressure Regulators  
 130 – 3/4" HDPE Service Line  
 60 – 1 1/2" SCH40 Encasement

Proposed 4" PVC C900 DR18 Waterline install 5' from and Parallel to R/W Line at 48" Minimum Cover

**STA 253+25**

**STA 278+25**

**Proposed Infrastructure**  
 ● Proposed Water Meter  
 + Proposed Valve  
 + Proposed Water Line  
 + System Valve  
 -W- Water Main  
 □ Property Line

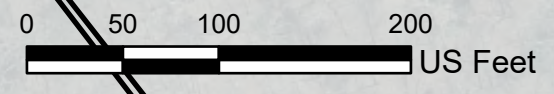

DRAWN BY: AO  
 CHECKED BY:  
 CHECKED BY:  
 DATE: 2/5/2025  
 SCALE: 1" = 100'

NO.	REVISIONS

Flint Hill Rd.  
 Waterline Extension  
 Hardin County, Kentucky

**Hardin County**  
**Water District No. 2**

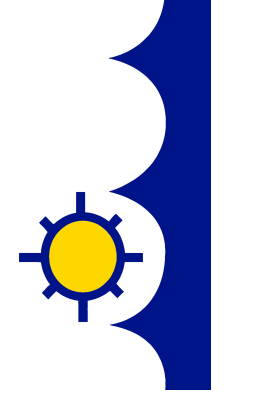



**STA 278+25**

No Easement

Deeded 20' Permanent WL  
& 10' Temporary  
Construction Easements

Proposed 4" PVC  
C900 DR18 Waterline  
install 5' from and  
Parallel to R/W Line  
at 48" Minimum Cover

No Easement

**STA 303+03**

20'  
Install Type II  
Blow Off Pipe

Do not flush w/o  
Melrose in place.  
Use this Blowoff  
to flush all of  
Flint Hill Rd.

Install Tee Configuration  
(1) 4" MJDI Tee  
(2) 4" Gate Valve

Main Line needs  
to stay closed.  
Connects Purple  
to Brown Zone.

No Easement

**End Const**  
**STA 309+25**

Tie Into Existing  
Type II Blowoff  
(1) 6" x 4" Reducer

Deeded 20' Permanent WL  
Easements

**Waterline Quantities**

- 3,120 l.f. - 4" PVC C900 DR 18 Pipe
- 60 l.f. - 12" Bare Steel Casing 0.250 Wall
- 1 - 4" MJDI Tee
- 3 - 4" Gate Valve
- 1 - 4" MJDI 45° Bend
- 6 - 4" MJDI Restraint
- 1 - 6" MJDI Restraint
- 3 - 4" Foster Adapter w/ Accessories
- 1 - 6" x 4" MJDI Reducer
- 1 - 4" x 3/4" Saddle for C900
- 1 - 3/4" Corporation Stop
- 1 - 3/4" Meter Setter
- 1 - 5/8" x 3/4" Meter
- 1 - Meter Box Combo
- 10 - 3/4" HDPE Service Line



DRAWN BY: AO
CHECKED BY:
CHECKED BY:
DATE: 2/5/2025
SCALE: 1" = 100'
REVISIONS

Flint Hill Rd.  
Waterline Extension  
Hardin County, Kentucky

Hardin County  
Water District No. 2

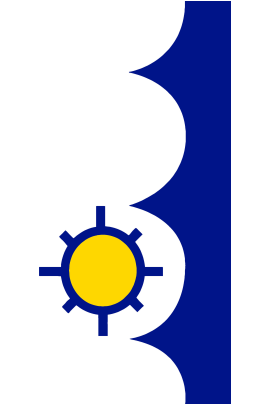

SHEET NO.  
18

**Proposed Infrastructure**

- Proposed Water Meter
- ⊕ Proposed Valve
- ⊕ Proposed Water Line
- ⊕ System Valve
- W- Water Main
- Property Line

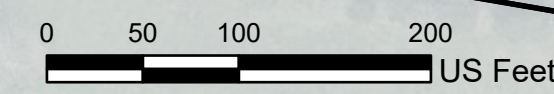

COT-Division of Geographical Information, NVS Geospatial, powered by Quantum Spatial

HIGHWAY / RAILROAD BORE DETAIL

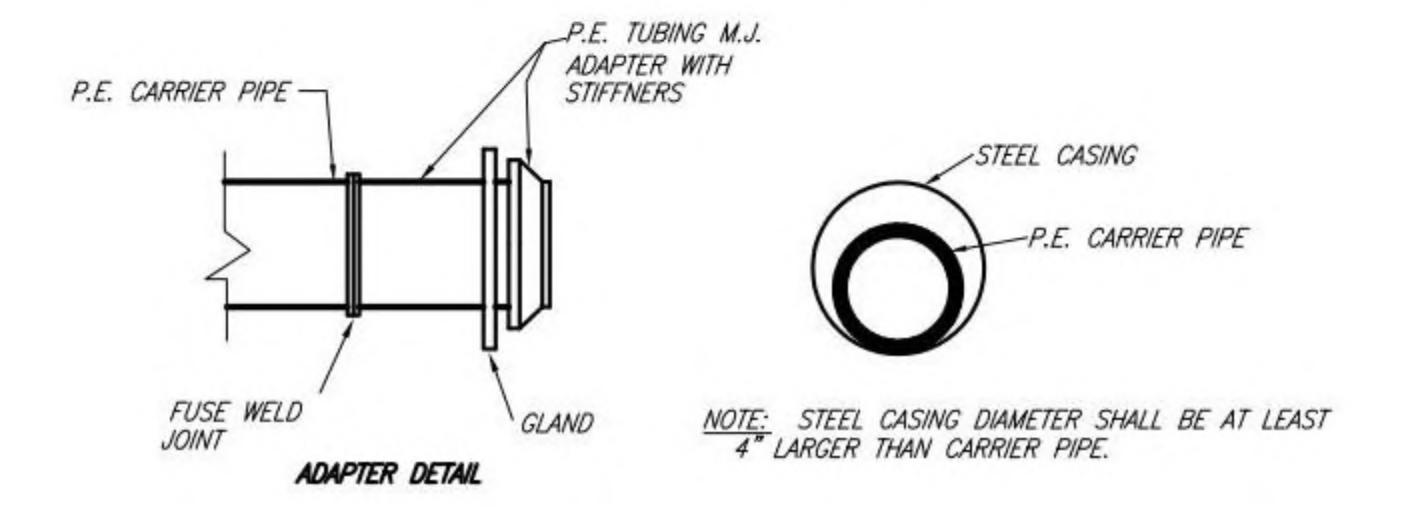
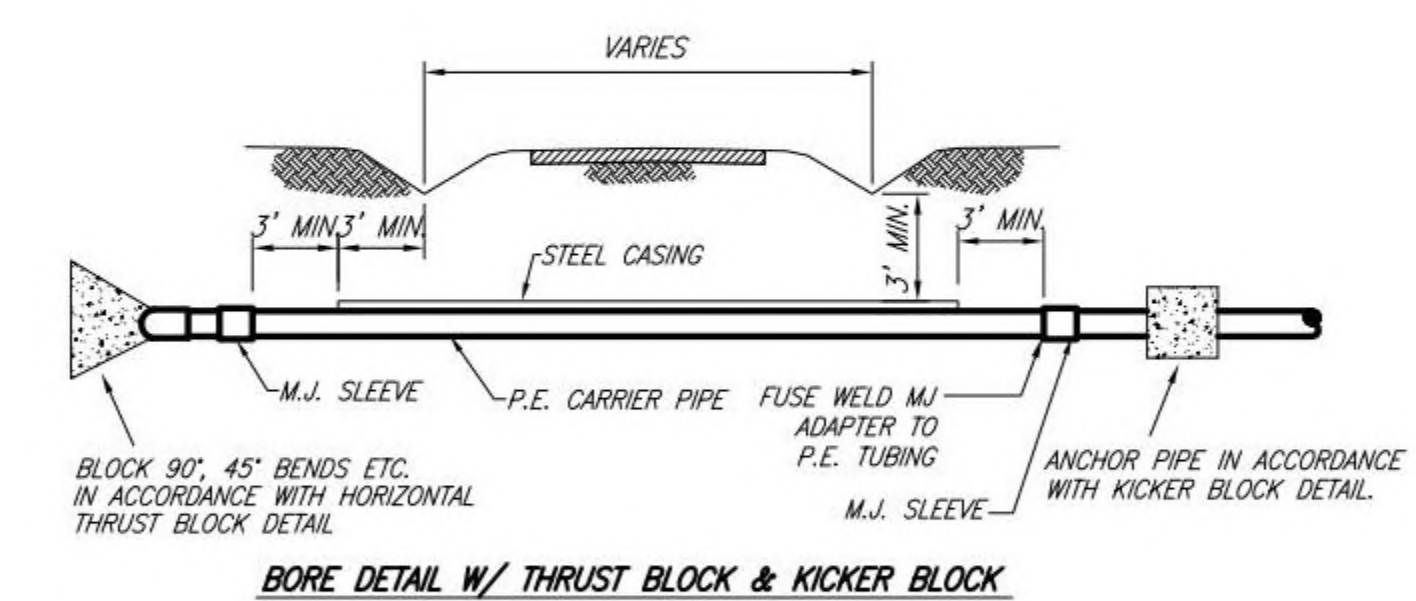
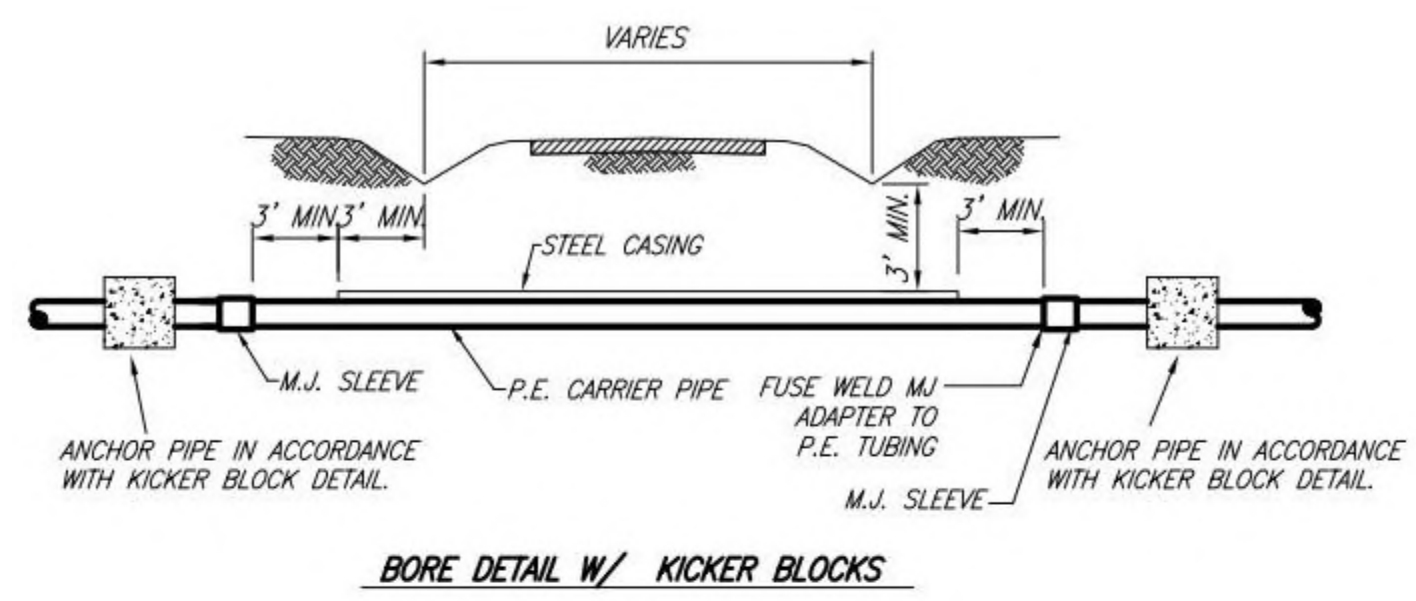

HORIZONTAL THRUST BLOCK DETAIL

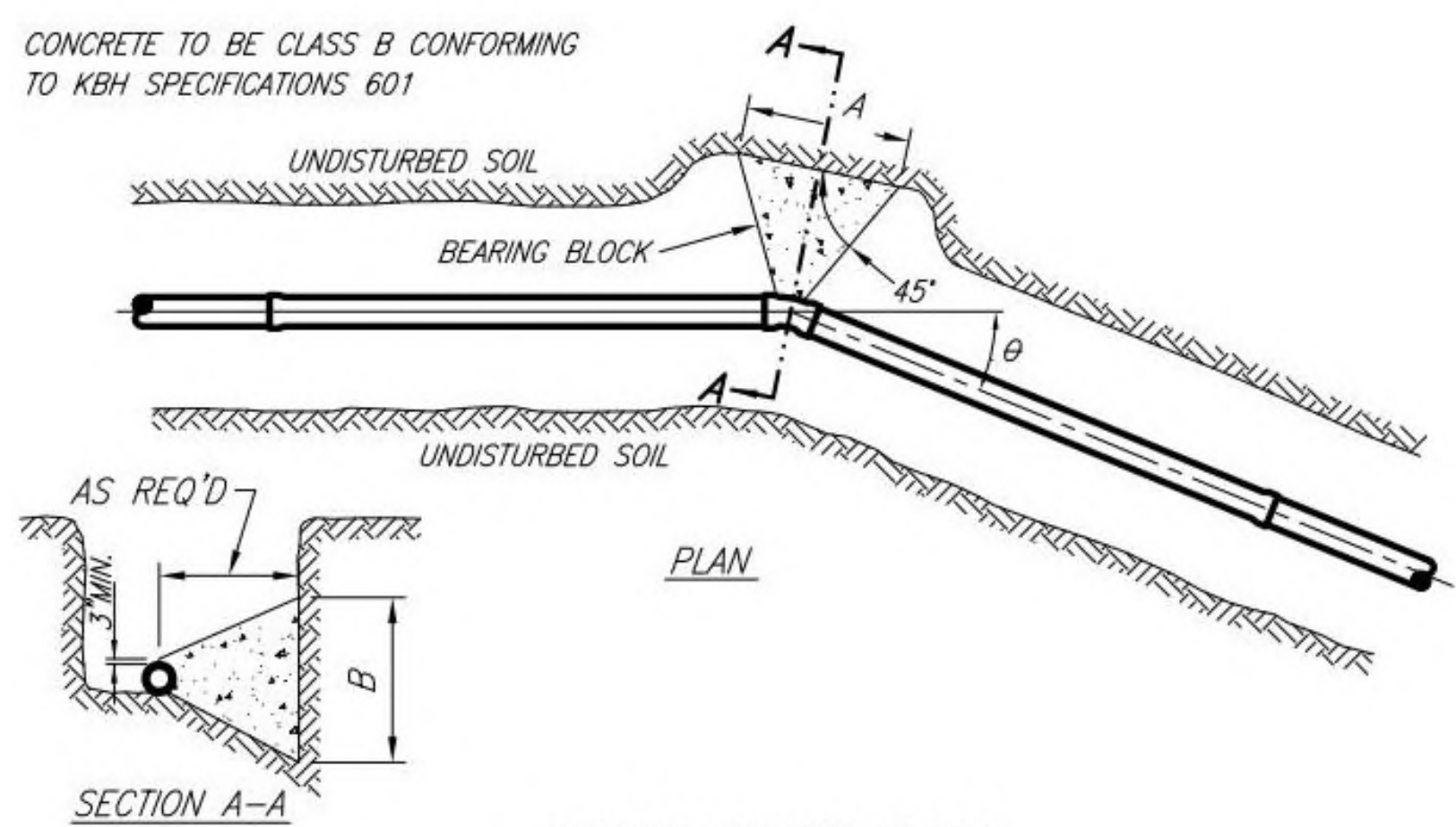

GRAVITY THRUST BLOCK

- NOTES:
- THRUST RESTRAINT TABLE IS BASED ON PIPELINE PRESSURE OF 200 PSI AND EARTH BEARING CAPACITY OF 1500 PSF. DURING CONSTRUCTION, AT THE REQUEST OF THE CONTRACTOR, THE SPECIFIC SOIL TYPE AND/OR THE PIPE WORKING PRESSURE MAY BE EVALUATED AND CONCRETE THRUST BLOCK SIZE REVISED AT THE DISCRETION OF THE ENGINEERING.
  - ON LARGE DIAMETER PIPES WHERE SPACE LIMITATIONS OR CONSTRUCTION DIFFICULTIES RENDER CONCRETE THRUST BLOCKS NOT FEASIBLE OR IMPRACTICAL, DUCTILE IRON RESTRAINED JOINT SYSTEM MAY BE USED. THIS RESTRAINED JOINT SYSTEM MUST BE APPROVED BY THE ENGINEER.

HORIZONTAL THRUST BLOCK SCHEDULE

PIPE SIZE (INCHES)	90° BEND		45° BEND		22.5° BEND		11.25° BEND		TEE, DEAD END	
	A	B	A	B	A	B	A	B	A	B
4	3'-3"	1'-8"	2'-4"	1'-2"	1'-8"	1'-0"	1'-0"	1'-0"	2'-8"	1'-4"
6	4'-8"	2'-4"	3'-5"	1'-8"	2'-6"	1'-3"	1'-6"	1'-0"	3'-10"	2'-0"
8	6'-0"	3'-0"	4'-5"	2'-3"	3'-2"	1'-7"	2'-3"	1'-2"	5'-0"	2'-6"
10	7'-6"	3'-9"	5'-5"	2'-9"	3'-10"	2'-0"	2'-9"	1'-5"	6'-3"	3'-2"
12	8'-10"	4'-5"	6'-6"	3'-3"	4'-8"	2'-4"	3'-4"	1'-8"	7'-5"	3'-9"
14	10'-3"	5'-2"	7'-6"	3'-9"	5'-4"	2'-8"	3'-10"	2'-0"	8'-8"	4'-4"
16	11'-8"	5'-10"	8'-7"	4'-4"	6'-1"	3'-0"	4'-4"	2'-2"	9'-9"	4'-11"
18	13'-0"	6'-6"	9'-7"	4'-9"	6'-10"	3'-5"	4'-10"	2'-5"	11'-0"	5'-6"
20	14'-5"	7'-3"	10'-7"	5'-4"	7'-7"	3'-9"	5'-4"	2'-8"	12'-2"	6'-1"
24	17'-3"	8'-8"	12'-8"	6'-4"	9'-0"	4'-6"	6'-5"	3'-3"	14'-6"	7'-3"

TAPPING SLEEVE & VALVE DETAIL

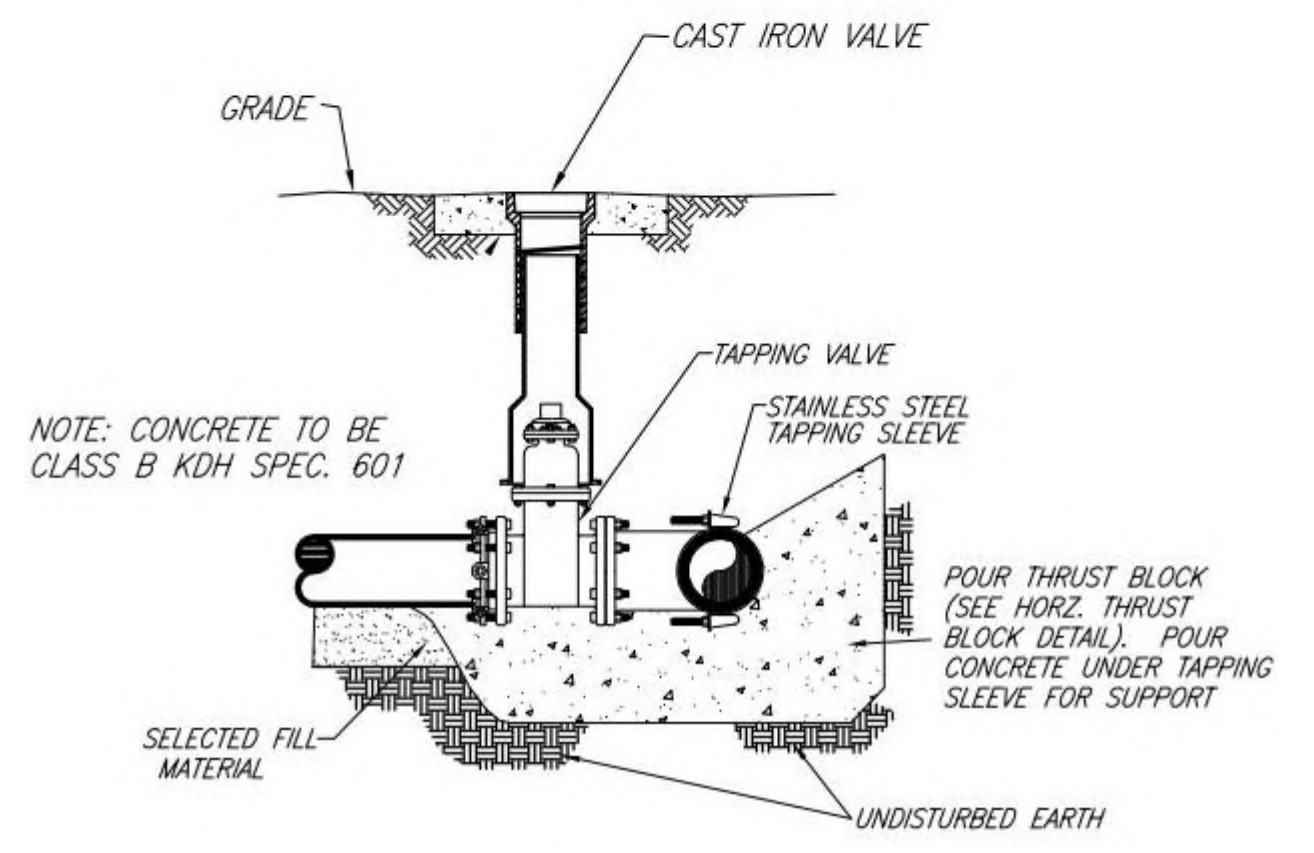
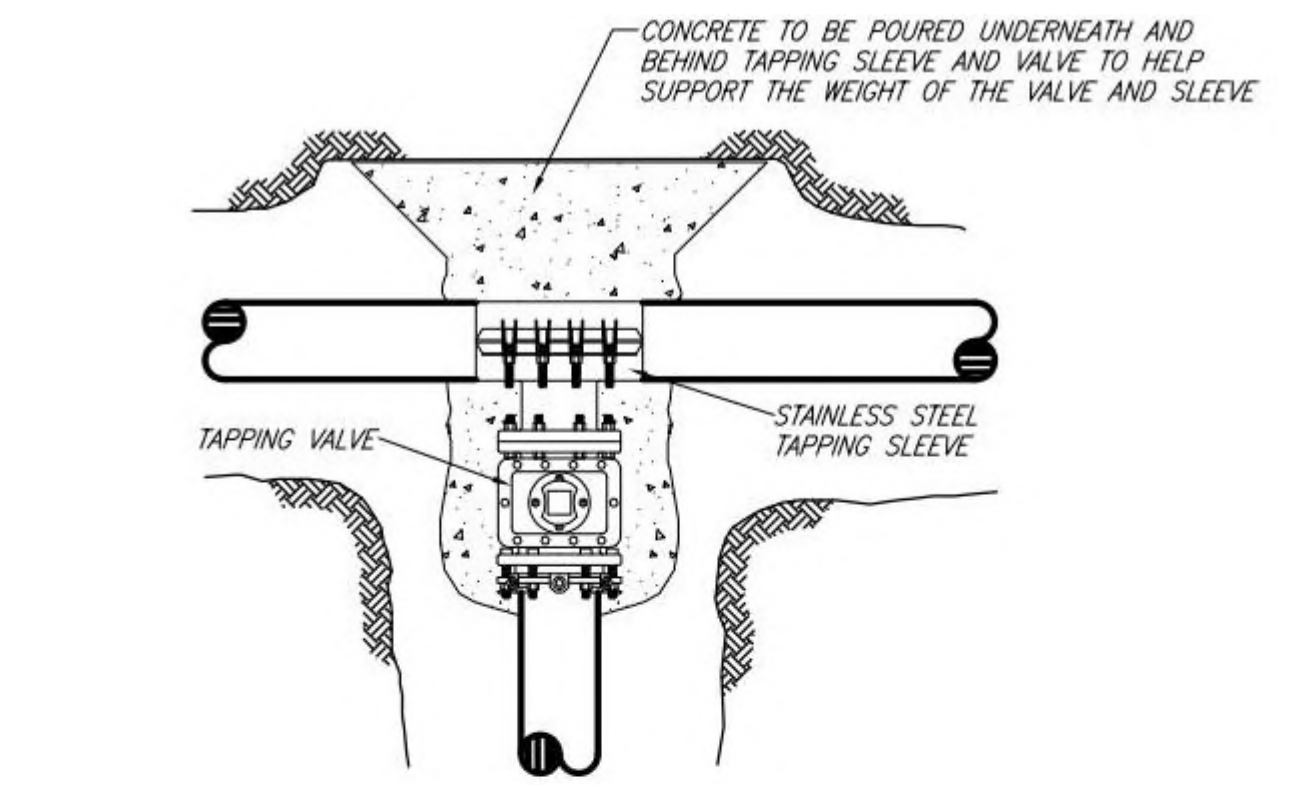

GRAVITY THRUST BLOCK

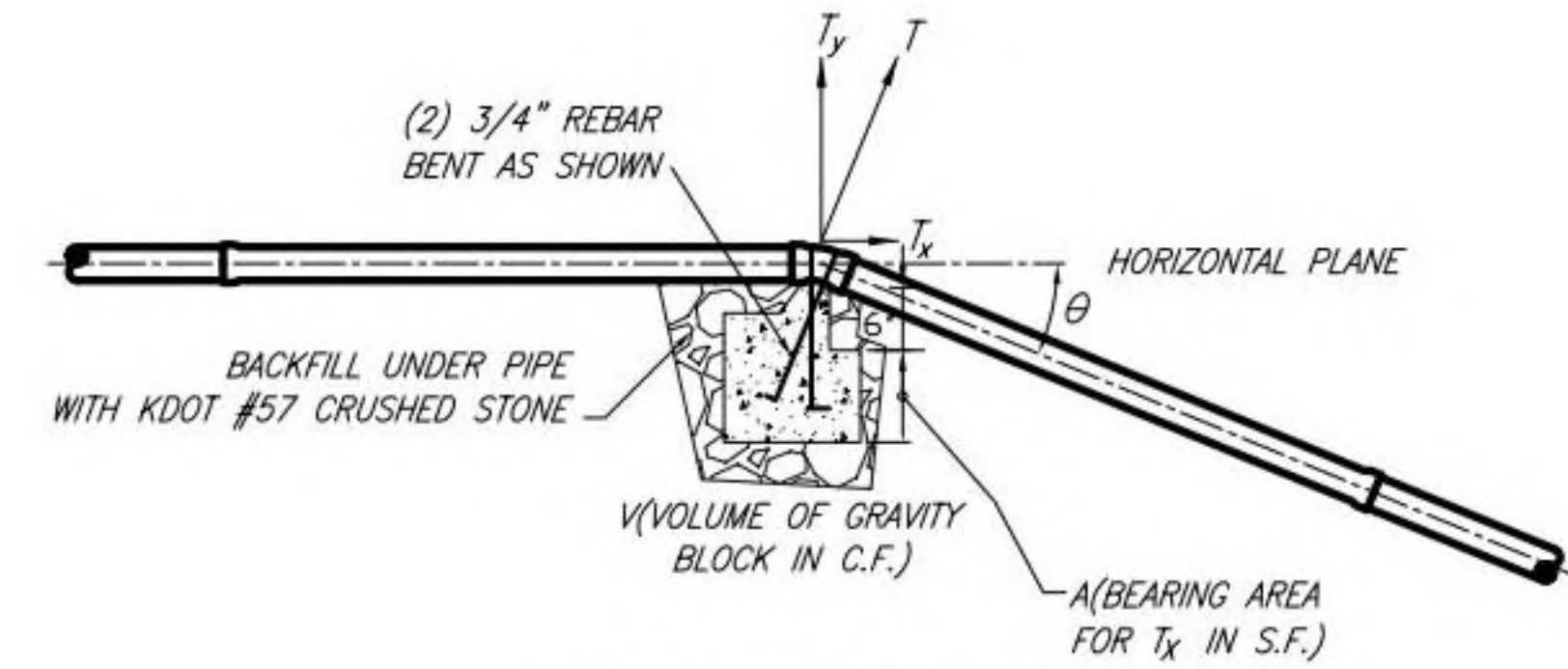

- NOTES:
- THRUST RESTRAINT TABLE IS BASED ON PIPELINE PRESSURE OF 200 PSI & EARTH BEARING CAPACITY OF 1500 PSF. DURING CONSTRUCTION, THE SPECIFIC SOIL TYPE MAY BE EVALUATED AND CONCRETE THRUST BLOCK SIZE REVISED AT THE DISCRETION OF THE ENGINEER.
  - ON LARGE DIAMETER PIPES WHERE SPACE LIMITATIONS OR CONSTRUCTION DIFFICULTIES RENDER CONCRETE THRUST BLOCKS NOT FEASIBLE OR IMPRACTICAL, A COMBINED JOINT RESTRAINT SYSTEM MAY BE USED. THIS COMBINED SYSTEM MUST BE APPROVED BY THE ENGINEER.
  - CONCRETE SHALL BE 2500 PSI MINIMUM CONFORMING TO KDH SPECIFICATIONS 601.
  - ACCESSIBILITY TO FITTINGS SNA BOLTS MUST BE MAINTAINED.

VERTICAL THRUST BLOCK SCHEDULE

PIPE SIZE (INCHES)	90° BEND		45° BEND		22.5° BEND		11.25° BEND	
	V	A	V	A	V	A	V	A
4	29	2	20	1	11	1	6	1
6	64	5	46	2	25	1	13	1
8	114	8	81	4	43	1	23	1
10	174	12	123	5	66	2	35	1
12	248	17	176	8	95	2	50	1
14	337	23	238	10	128	3	67	1
16	439	29	311	13	167	4	88	1
18	555	37	393	16	211	5	111	1
20	685	46	484	20	260	6	137	2
24	985	66	696	29	374	8	197	2

TYPE II BLOWOFF DETAIL

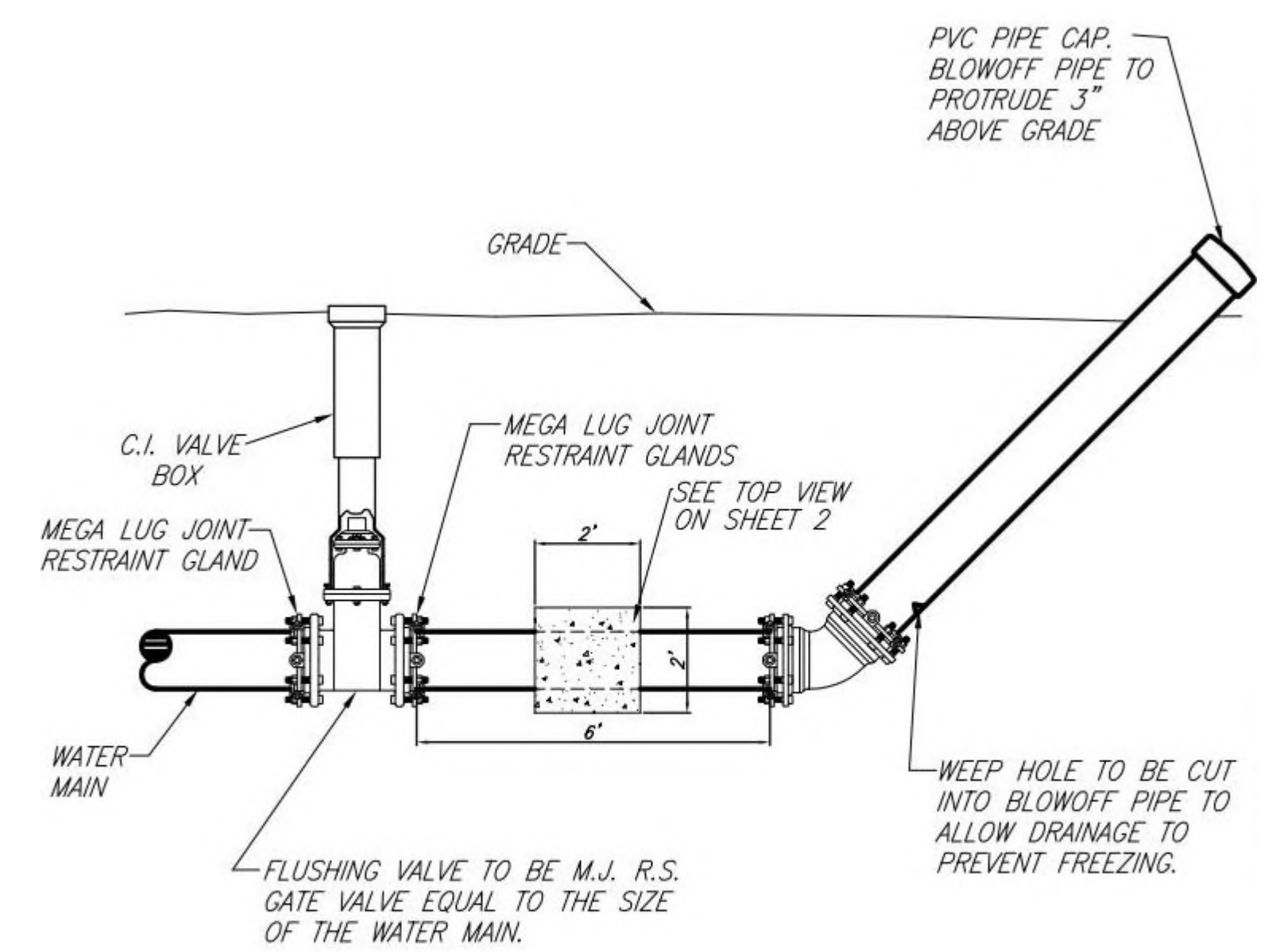

LAYING CONDITIONS

STANDARD ANSI/AWWA C150/A21.50 LAYING CONDITIONS

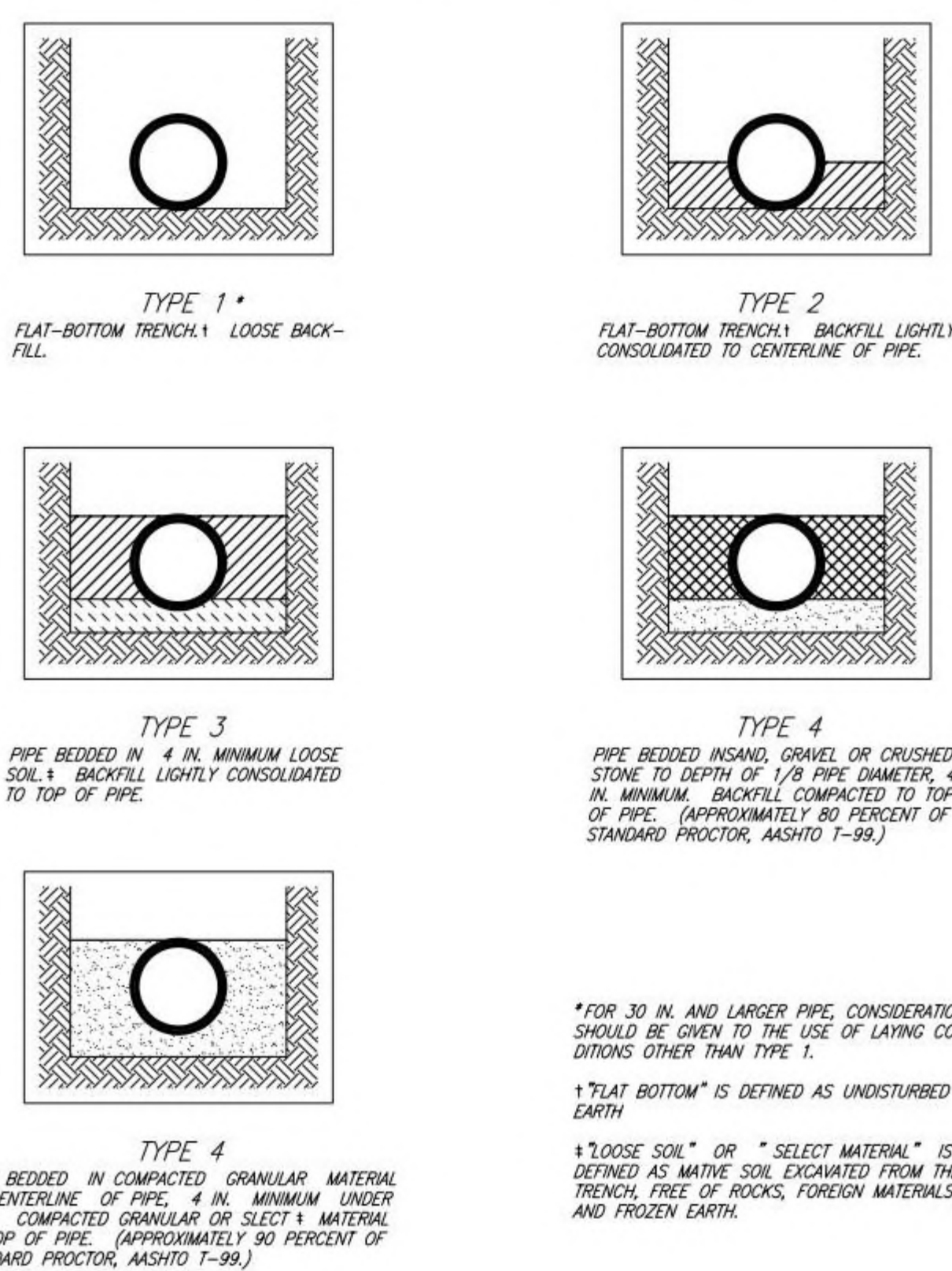

VALVE BOX DETAIL

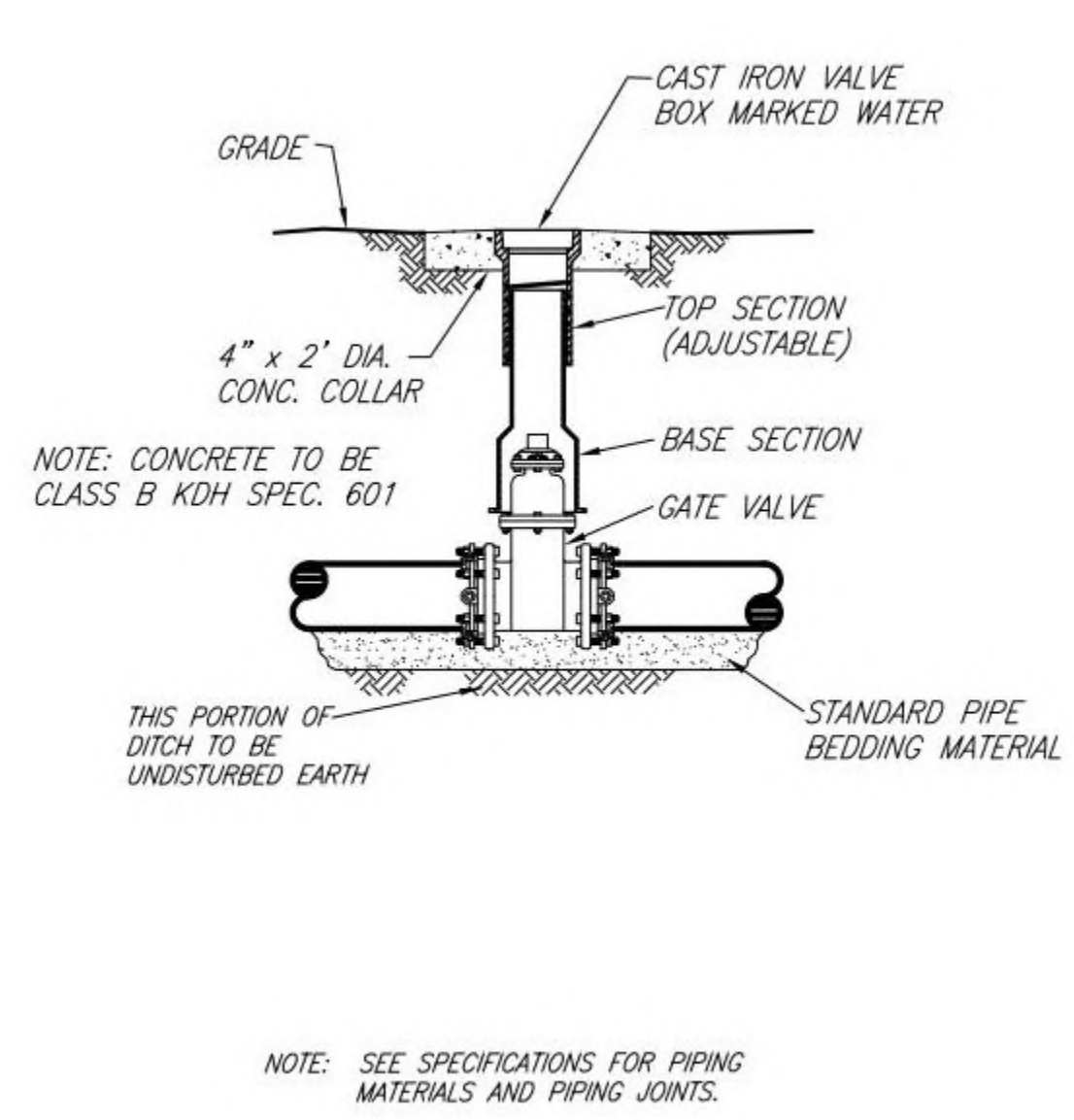

TRACER WIRE DETAIL

