



Hardin County Water District No. 2

Fire Service Agreement

This Agreement is a Fire Service Agreement entered into between _____, the Customer and Hardin County Water District No. 2, the District.

Conditions of the Agreement are as follows:

- ~~A hydraulic analysis, paid by the Customer, must be conducted to determine if proper fire flows meet state and/or local requirements on the site to where the vault is to be located before any work is to commence.~~
- The Customer shall construct a fire service vault in accordance with the District's Fire Vault Drawing. Interior depth of the vault shall conform to the chart on the detailed drawing.
- Before any work is to commence, a preconstruction meeting shall be scheduled with the Customer, Contractor, and the District. The District will inspect the installation of the vault during construction. Once construction is completed and passes inspection, the District shall own and maintain the vault.
- The Customer shall be charged a monthly fire service fee for District costs to, read the meter and maintain the fire service vault. The monthly service fee is based on current District rates plus applicable taxes and is subject to adjustment based on future rates. Any leak detected on the customer fire line shall be promptly repaired.

Size of Service: _____

Monthly Service Fee: _____

Size	Fee
4"	\$32.00
6"	\$32.00
8"	\$48.00
10"	\$72.00
12"	\$106.00

- No charge is made for flow going through the Detector Backflow Device when used for emergency purposes. However, a multiplier of 2 times from the water registered through the indicator meter will be used to determine the amount of water used and will be billed at the District's current water rates.



Hardin County Water District No. 2

Fire Service Agreement

6. The Customer is responsible to utilize a professional engineer or other licensed professional to analyze and select proper sizing based on flow and pressure requirements of the Customer and capabilities of the District.

7. The District will not maintain, warrant, repair, or replace any appurtenances, controls, or equipment placed inside the vault that is not part of the District's Fire Vault Detail Drawing. Furthermore, the District will not be responsible for any damages to such appurtenances, controls, or equipment caused by flooding or other occurrences including damages caused by the District during the normal course of maintenance.

8. The District shall warrant the normal capabilities of the District system. The Customer recognizes that the system, due to abnormal events such as line breaks, pumping station or tank maintenance emergencies, is not guaranteed to provide customer flow and pressure requirements at all times.

Customer

Date

District Representative

Date

Service Address: _____

Parcel #: _____

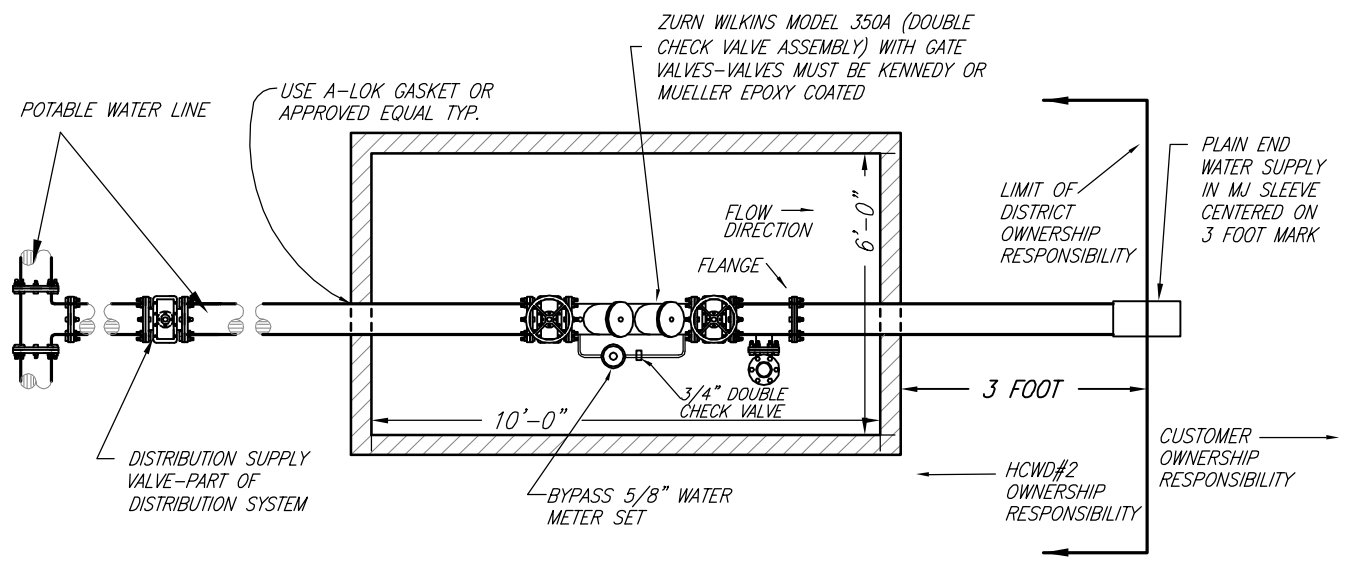

30"x30" DOOR AND FRAME SHALL HAVE A HASP, AS REQUIRED FOR HCWD#2 TO INSTALL A PAD LOCK ON THE DOOR AND FRAME ASSEMBLY

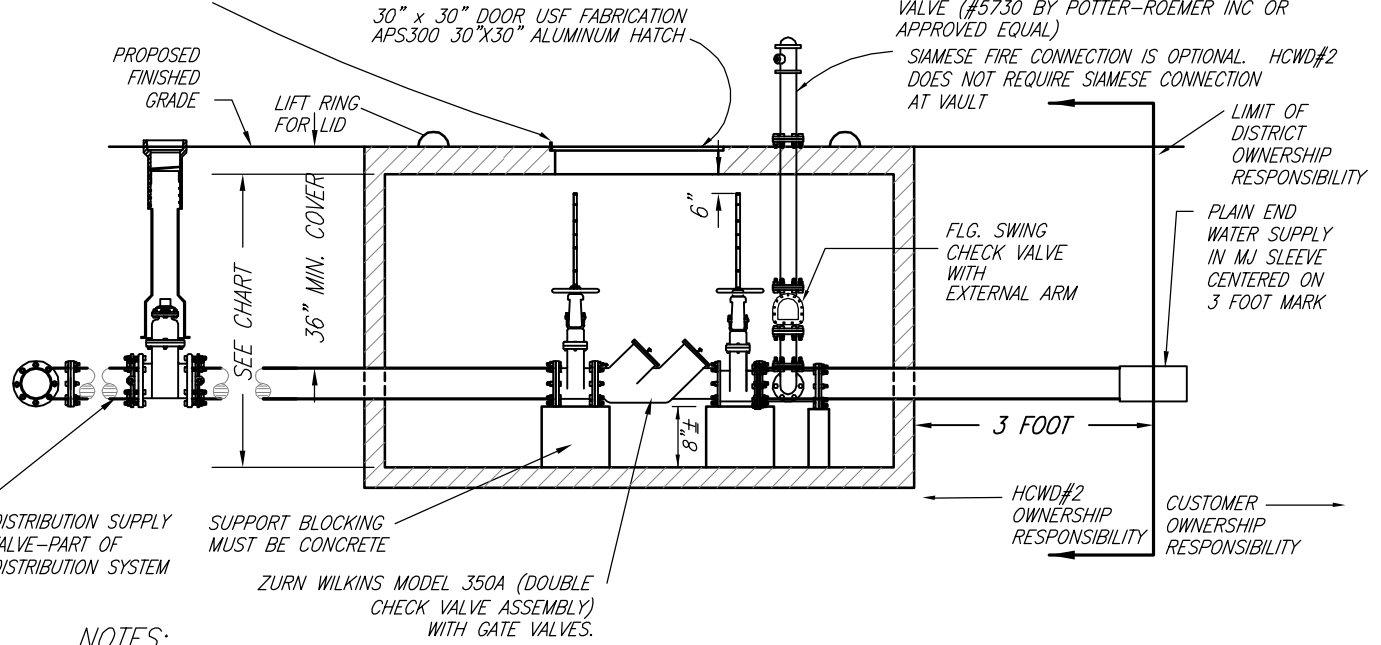

NOTES:

1. CONCRETE AND REINFORCING SHALL CONFORM TO THE STANDARD SPEC'S.
2. APPURTENANCES AND VAULT ARE FOR DISTRICT USE ONLY. NO ACCESS WILL BE GRANTED OR CONNECTIONS MADE INSIDE THIS VAULT.
3. ALTERNATE VAULT SIZE & MATERIAL MAY BE SUBMITTED TO HCWD#2 FOR APPROVAL.
4. THE DISTRIBUTION SUPPLY VALVE ON THE DISTRICT SIDE OF THE FIRE VAULT NEXT TO THE POTABLE WATER MAIN IS PART OF THE DISTRICTS' DISTRIBUTION SYSTEM & SHOULD NOT BE MONITORED.

VALVE SIZE	INSIDE HEIGHT VAULT DIMENSION
2	33
2 1/2	34
3	38
4	41
6	50
8	60
10	68
12	76

NO.	REVISION	DATE	APPR. BY

**PROPOSED
FIRE SERVICE VAULT
4" TO 12"**

**SCALE: NOT TO SCALE
APPROVED BY: JJ**



**HARDIN COUNTY WATER
DISTRICT #2**

360 RING ROAD
P.O. BOX 970
ELIZABETHTOWN, KY 42702
(270) 737-1056

Z:\projects\DETAILS\F-010-2\FVAULTS-2015.dwg, 6/30/2015 10:21:08 AM, PDF995